



# Installation, Operation and Maintenance Modular Air-cooled Water Chiller (Heat Pump)

R410A

CXAJ/CGAJ065~130



690152850003

## SAFETY WARNING

Only qualified personnel should install and service the equipment. The installation, starting up, and servicing of heating, ventilating, and air-conditioning equipment can be hazardous and requires specific knowledge and training. Improperly installed, adjusted or altered equipment by an unqualified person could result in death or serious injury. When working on the equipment, observe all precautions in the literature and on the tags, stickers, and labels that are attached to the equipment.

April 2020

**PKGP-SVX18B-EN**

**TRANE**  
TECHNOLOGIES



## Foreword

We hope that you read this manual carefully before installation and use, understand all the functions and characteristics of the air conditioning unit, and install, operate and maintain the air conditioning unit in accordance with the manual, so as to ensure the normal and reliable operation of the air conditioning unit and avoid failure caused by improper operation.

This manual is the customer's property and is used in conjunction with the unit. Please put it back in the technical data bag after installation and keep it properly.

The manual contains "Confirmation Sheet of Installer's Request for Commissioning", which is used to verify that all necessary installation steps have been completed. This confirmation sheet cannot replace the contents of this manual. Read this manual carefully before installing the unit, and be sure to follow it!

This manual may not cover all situations encountered during the installation of the air-conditioning units. Please contact Trane's local sales office if more detailed information is required or customers' specific questions are not addressed in this manual. The contents of the manual will be changed with the improvement of machines from time to time without prior notice.

All installation procedures of the air conditioning unit shall comply with the national and local regulations and it shall be installed by professionals "**△WARNING**" and "**△NOTICE**" will be given in the manual where appropriate. In order to ensure the personal safety and the normal operation of the unit, please read these contents carefully and follow them strictly, as each of which is extremely important.

## Contents

<b>Foreword</b> .....	<b>2</b>	Inspection before Start-up .....	24
<b>Safety Precautions</b> .....	<b>3</b>	Unit Setting .....	25
<b>Unit Introduction</b> .....	<b>5</b>	<b>Unit Operation</b> .....	<b>27</b>
Nomenclature .....	5	Startup Step .....	27
Performance Data .....	6	Long-time Shutdown .....	27
Dimensions .....	8	System Start-up after Long-time Shutdown 27	
Application Range .....	9	System Protection .....	27
<b>Unit Installation</b> .....	<b>10</b>	<b>Module Control System</b> .....	<b>30</b>
Inspection before Installation .....	10	System Introduction .....	30
Unloading and Hoisting Requirements	10	Modular controller .....	30
Selection of Installation Location .....	11	Unit Address Dial Code Distribution .....	34
Requirements for Installation Space .....	11	Functions of Modular controller .....	35
Installation of Water System .....	14	<b>Building Control System</b> .....	<b>40</b>
Water Treatment Requirements .....	18	<b>Troubleshooting</b> .....	<b>41</b>
<b>Electrical Installation</b> .....	<b>19</b>	Fault Codes .....	41
Safety Precautions .....	19	Common Faults and Handling Methods	42
Electrical Wiring .....	19	<b>Maintenance and Service</b> .....	<b>45</b>
Electrical Specification .....	20	<b>Environmental Safety Warning</b> .....	<b>48</b>
Electrical Circuit Diagram .....	21		
<b>Pilot Run</b> .....	<b>24</b>		



## Safety Precautions

**⚠ WARNING** — There will be a risk of serious damage to the air conditioning unit or casualty if the manual is not strictly followed.

**⚠ NOTICE** — If the manual is not strictly followed, there will be a risk of light or moderate damage to the air conditioning unit, property damage, personal injury or environmental pollution. It also provides useful help information which may be beneficial to the operation of the unit or to the service life extension of the unit. However, it does not indicate that the help information is optimal or directly related to the improvement of unit operation.

### ⚠ WARNINGS

- All installation procedures of the air-conditioning unit shall conform to the national and local regulations.
- For the installation of the equipment, please consult with the local sales office. Professional technicians with the installation certificate of air conditioning unit shall be required to install the air conditioning unit. Users shall not install, repair or move the air conditioning unit. If the users construct by themselves, leakage, electric shock or fire may be caused.
- Before installation or maintenance, lock the power supply and the cut-off switch of the unit in the power-off state to avoid personal injury caused by electric shock or contact with a moving part.
- Please set up a dedicated circuit. The fluctuation of voltage supply shall not exceed 10% of the rated voltage. The power supply line must be separated from the welding transformer, which will cause large voltage fluctuation.
- Professional electricians with certificates shall be required to strictly carry out installation operations in accordance with the national power standards and the regulations of the local power department, inspect whether the line capacity meets the requirements and whether the power line is loose or damaged.
- The cover plate of the electric cabinet must be firmly installed to prevent dust, water and other foreign matters from entering. The electrical part must be moisture-proof and away from water source, or it will cause electric shock, fire and other accidents.
- Please use the fuse with correct current strength. Do not use temporary substitutes, such as a piece of wire. This may not only damage the unit itself, but also cause fire.
- The power supply and electric auxiliary heating power supply of the unit must be equipped with leakage protection devices, and the earth wire must be connected, otherwise there will be injuries or even casualties and other accidents in the absence of protection.
- All electric auxiliary heating wires shall be connected in accordance with the wiring diagram. Directly energizing the electric auxiliary heating wires will lead to the failure of some control functions of the unit and damage the unit.
- Please strictly follow the wiring diagram in this manual. Incorrect wiring or manual wiring change will cause unit failure, damage or personal safety.
- When cleaning the unit, do not sprinkle water directly on the unit, which may cause electric shock.
- Cut off all power supplies before contacting the wiring device.
- Before maintenance, please confirm that the unit is in the power-off state.
- Maintenance can only be carried out by professional maintenance personnel. For maintenance and repair, contact Trane sales office. Improper maintenance and repair may result in water leakage, electric shock or fire.
- Do not use flammable materials (e.g. hairspray or pesticides) near this product. Do not clean the product with organic solvents such as paint thinner.
- Cracks, electric shock or fire may be caused if organic solvents are used.
- Optional accessories shall be installed by professionals. Be sure to use the optional accessories designated by the company. Improper.
- Do not use unqualified refrigerants, refrigerant substitutes or refrigerant additives. Incorrect use method or use of



unqualified refrigerants, refrigerant substitutes or refrigerant additives will cause damage to the unit and various safety risks. Please select qualified refrigerant or call 8008208676 to purchase qualified refrigerant. All technicians operating refrigerants must be certified, and be familiar with and strictly comply with the relevant technical requirements, laws and regulations regarding the use, handling, recovery and recycling of refrigerants.

- No open flames are allowed when the refrigerant leaks. If the air conditioning unit fails to refrigerate or heat properly, the refrigerant may leak. Contact Trane sales office at this time.
- The refrigerant used in the air conditioning unit will not leak in normal conditions. In case of indoor refrigerant leakage, toxic gases will be produced after the refrigerant is in contact with the flame of heater, electric furnace and stove. Please extinguish the fire of the burning appliances, ventilate the room and contact Trane sales office.
- When the unit is repaired in case of refrigerant leakage, please operate the machine after the maintenance personnel confirm that the leakage repair is completed.
- Do not start the air conditioning unit when the panel or protective net is removed. Rotating parts in the air conditioning unit may injure people or other articles.
- Prevent objects, such as sticks, sand or stones, from entering the air inlet or outlet grid. The fan rotates at high speed and is very dangerous. Special care must be taken of children.
- The strength of ordinary air conditioner support may not be suitable for this product. Please choose the support according to the weight design of the unit. The support with insufficient bearing strength will cause great safety accidents and hidden dangers.
- In the seasons with frequent use of air conditioning unit and if the machine stops using for a short period of time in winter, please keep the machine in the power-on state to ensure that the machine can be normally anti-freezing. Otherwise, the machine may be frozen to be out of service.
- If the system is powered on for the first time or used after the power supply is cut off for a long time, it shall be powered on for 24 hours before starting up, so as to ensure that the unit is fully preheated, otherwise it may cause the burning of compressor.
- In the season when the air conditioning unit is not used for a long time, please cut off the main power supply of the system to extend the service life of the unit and save electrical energy.

## NOTICES

- Do not touch the fins of the heat exchanger. Otherwise, it may damage the fins to cause the reduction of machine performance or cut fingers.
- After the installation, the air tightness test shall be carried out on the pipeline to check whether the pipeline leaks.
- Do not touch the refrigerant pipeline during or immediately after the operation of the unit. When the air conditioning unit runs, the pipeline may be very hot or cold, leading to burn or frostbite.
- Do not sit on the direct air duct for a long time. Long-time sitting on the direct air port is not good for your health. Special attention should be paid when you sleep or there is an infant, the elderly or the sick in the room.
- Do not place the heating device or other heat sources under or near the air conditioning unit. The machine body will be deformed after being heated.
- Whenever you operate the unit, make sure the air filter is properly installed. Otherwise, dirt may enter into the internal moving parts and cause damage.
- Do not block or cover the inlet or outlet grid. This may cause performance degradation and affect the normal running ability.
- The chassis of the outdoor unit is provided with a defrosting waterspout ensure the smooth water drainage of the unit.
- It is recommended that the snow shade be installed for the outdoor unit to ensure the better operation of the machine on snowy days. Installation may cause water leakage, electric shock and fire.



# Unit Introduction

## Nomenclature

**Model**     C X A J 0 6 5 5 B  
                   1  2  3  4  5  6  7  8  9

**Additional options**    1 H S F R A M A A  
                                   10 11 12 13 14 15 16 17 18

**Maintenance code**    C X A J 0 6 5 5 B 1 H S F R A M A A  
                                   1  2  3  4  5  6  7  8  9 10 11 12 13 14 15 16 17 18

Digit 1	C = Chiller
Digit 2	X = Heat pump G = Cooling only
Digit 3	A = Air cooled
Digit 4	J = Modular type
Digit 5,6,7	Model (cooling capacity) 065 (65kW) 130 (130kW)
Digit 8	Voltage/Hertz/Phase 5 = 380V/50Hz/3PH
Digit 9	Design Sequence B = R410A
Digit 10	Fan speed 1 = Single speed
Digit 11	Energy efficiency N = Standard efficiency H = High efficiency
Digit 12	Controller S = Modular controller (units ≥ 2) U = Unit controller (unit = 1) N = None
Digit 13	Service Sequence F = 6th time
Digit 14	Ambient temperature R = Standard
Digit 15	Connector option A = Without 2 pcs. of DN125 rubber connectors B = With 2 pcs. of DN125 rubber connectors
Digit 16	BMS interface M = Modbus component N = NONE
Digit 17	Refrigerant charged A = Without B = With
Digit 18	Option A = Default B = Special requirement



## Unit Introduction

### Performance Data

Standard-efficiency Model (N type)

Model		CXAJ065	CXAJ130	CGAJ065	CGAJ130	
Cooling	Rated Cooling Capacity	kW	65	130	65	130
	Rated Input Power	kW	21.6	43.20	21.6	43.20
	Rated Operating Current	A	42.0	81.0	42.0	81.0
Heating	Rated Heating Capacity	kW	67	137	-	-
	Rated Input Power	kW	21	41.00	-	-
	Rated Operating Current	A	41.5	74.0	-	-
Max. Operating	Max. Input Power	kW	29.2	60	29.2	60
	Max. Current	A	55	120	55	120
Compressor	Category		Hermetic scroll			
	No.	Pieces	2	2	2	2
	Rated Cooling Power	kW	10.1	20.0	10.1	20.0
	Rated Cooling Current	A	19.2	38.0	19.2	38.0
	Rated Heating Power	kW	9.5	19.0	-	-
	Rated Heating Current	A	18.5	34.0	-	-
Refrigerant	Category		R410A			
	Charge	kg	13	12.5*2	13	12.5*2
Water Side	Category of Heat Exchanger		High-efficiency shell-tube heat exchanger			
	Rated Water Flow	CMH	11.2	22.4	11.2	22.4
	Water Pressure Drop	kPa	60	70	60	70
	Connections	mm	DN125	DN125	DN125	DN125
Air side	Category of Heat Exchanger		High-efficiency fin-coil heat exchanger			
	Fan No.	Pieces	2	2	2	2
	Rated Input Power of Fan	kW	0.75	1.5	0.75	1.5
	Rated Current of Fan	A	2.1	3.96	2.1	3.96
	Air Flow	CMH	12000	20000	12000	20000
Unit	Power Supply		380/3N~/50			
	Noise	dB(A)	69	70	69	70
	Net Weight	kg	710	1050	710	1050
	Operating Weight	kg	780	1150	780	1150
Dimension	Length	mm	2145	2400	2145	2400
	Width	mm	1000	1200	1000	1200
	Height	mm	2155	2380	2155	2380



## Unit Introduction

## High-efficiency Model (H type)

Model			CXAJ065	CXAJ130	CGAJ065	CGAJ130
Cooling	Rated Cooling Capacity	kW	65	130	65	130
	Rated Input Power	kW	21.0	40.9	21.0	40.9
	Rated Operating Current	A	40.5	78.0	40.5	78.0
Heating	Rated Heating Capacity	kW	67	137	-	-
	Rated Input Power	kW	21.5	40.00	-	-
	Rated Operating Current	A	41	71.0	-	-
Max. Operating	Max. Input Power	kW	29.2	57.2	29.2	57.2
	Max. Current	A	55.0	98.2	55.0	98.2
Compressor	Category		Hermetic scroll			
	No.	Pieces	2	4	2	4
	Rated Cooling Power	kW	9.2	9.2	9.2	9.2
	Rated Cooling Current	A	18	18	18	18
	Rated Heating Power	kW	9.1	9.1	-	-
	Rated Heating Current	A	18	18	-	-
Refrigerant	Category		R410A			
	Charge	kg	15	15*2	15	15*2
Water Side	Category of Heat Exchanger		High-efficiency shell-tube heat exchanger			
	Rated Water Flow	CMH	11.2	22.4	11.2	22.4
	Water Pressure Drop	kPa	60	70	60	70
	Connections	mm	DN125	DN125	DN125	DN125
Air side	Category of Heat Exchanger		High-efficiency fin-coil heat exchanger			
	Fan No.	Pieces	2	2	2	2
	Rated Input Power of Fan	kW	0.75	1.5	0.75	1.5
	Rated Current of Fan	A	2.1	3.96	2.1	3.96
	Air Flow	CMH	12000	20000	12000	20000
Unit	Power Supply	V/PH/Hz	380/3N~/50			
	Noise	dB(A)	69	70	69	70
	Net Weight	kg	730	1150	730	1150
	Operating Weight	kg	800	1250	800	1250
Dimension	Length	mm	2145	2400	2145	2400
	Width	mm	1000	1200	1000	1200
	Height	mm	2155	2380	2155	2380

1. The cooling capacity is measured in the conditions of water outlet at 7°C and air inlet at the ambient temperature of 35°C .
2. The heating capacity is measured in the conditions of water outlet at 45°C and air inlet at the ambient dry bulb temperature of 7°C and the wet bulb temperature of 6°C .



## Unit Introduction

## Dimensions

### CX(G)AJ065

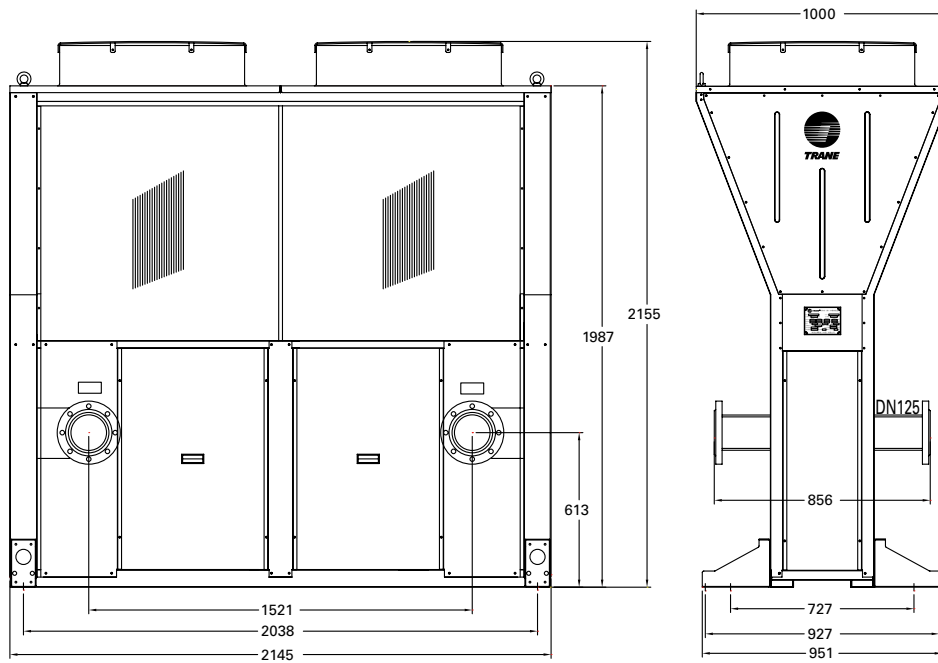

Outlet pipe is at near control box side, and inlet pipe is at far side of control box.

### C(G)XAJ130

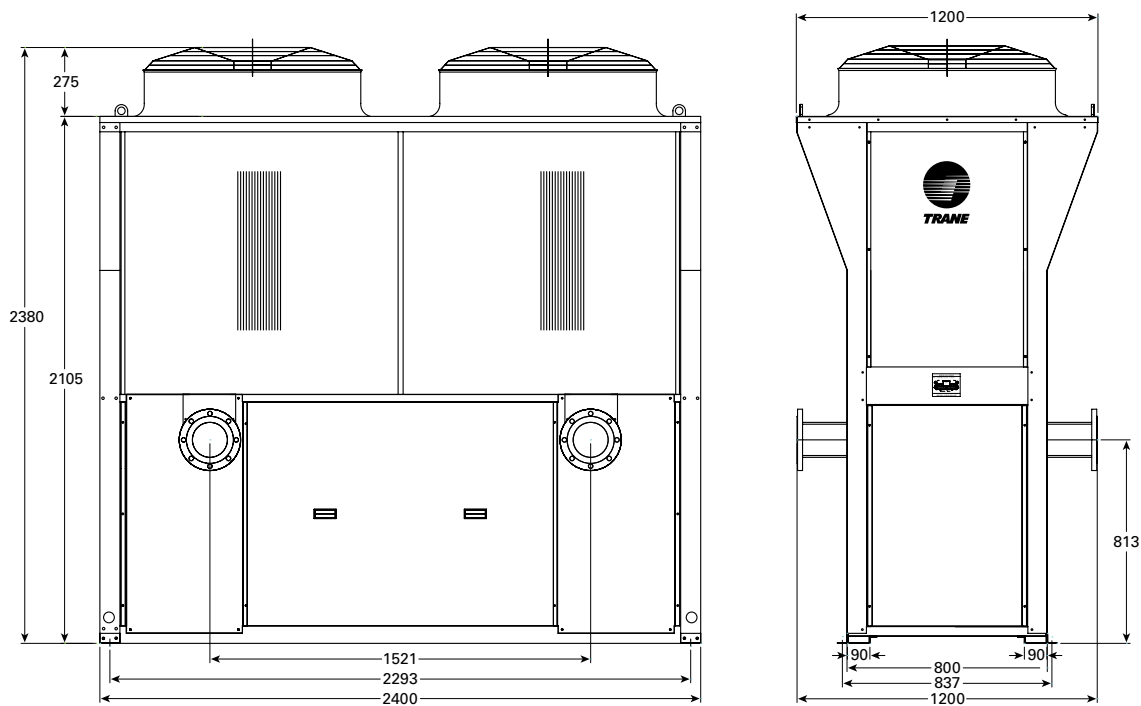

When facing to the electric cabinet. The left water pipe is outlet pipe, and the right water pipe is inlet pipe.



## Application Range

### Voltage range

The maximum allowable fluctuation range of supply voltage is 10%.

### Temperature range

Item	Range of Application
Range of unit operating ambient temperature	Cooling: 18~48°C (High efficiency), 18~46°C (Standard efficiency), Heating: -15~25°C
Range of unit operating water temperature	Cooling: 5~15°C Heating: 30~50°C
Range of controller operating ambient temperature	0~45°C
Relative humidity	< 90%



# Unit Installation

## Inspection before Installation

1. Whether the nameplate of the unit is consistent with the model in the order;
2. Whether all the accompanying documents for the unit are available;
3. Whether the accessories of the unit are consistent with the items listed in the packing list;
4. Upon receipt of the unit, please carefully inspect whether the unit is damaged in transit. If any, please record it on the delivery note, notify the final carrier in writing within 72 hours and notify the local Trane sales office at the same time.

## Unloading and Hoisting Requirements

Please handle the unit to its installation position by using a forklift, crane or hoist with appropriate tonnage. During handling, keep the machine horizontal, and avoid damage to the unit due to reckless operation.

### Unit Hoisting Diagram

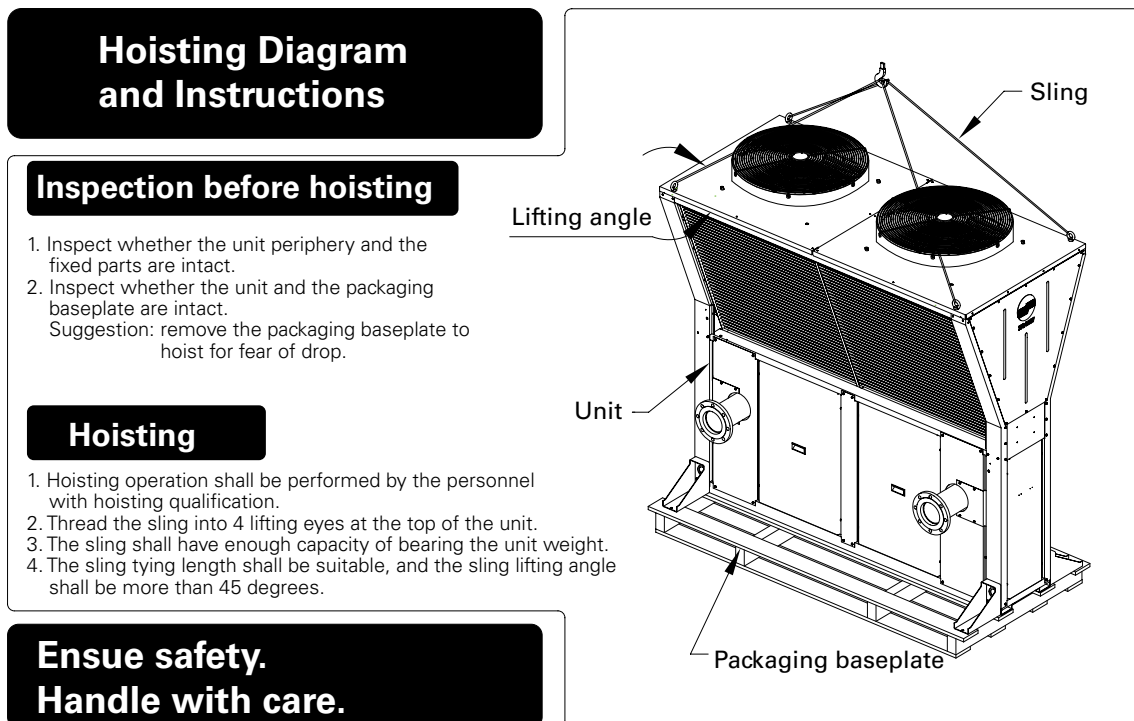

### Warning

During hoisting, ensure stable hoisting of the outdoor unit, and avoid uneven weight distribution of the unit. If the center of gravity is on the side of the compressor, trial operation should be performed before hoisting. Observe whether the sling is tied tightly and whether the unit is at the risk of toppling. When hoisting, rise slowly and evenly to prevent the unit from tipping over and ensure the safety of people around!



## Selection of Installation Location

1. The unit can be installed on the roof, the ground or other places which are convenient to install and can bear the load reliably;
2. It shall not be installed near other heat sources that may affect the normal operation of the unit;
3. It shall not be installed near the places with corrosive or flammable gases;
4. The operating noise and exhaust air of the unit should not affect the surrounding activity sites as much as possible;
5. If the unit is located in a place accessible to non-professional personnel, the protective isolation shall be installed;
6. The installation location shall ensure sufficient ventilation and maintenance space;
7. The unit shall be installed on a flat and horizontal plane. The mounting surface shall bear the weight of the unit. See the table of unit weight and outline dimensions;
8. It is better to install 8-10mm thick rubber shock pad between the units and its load to absorb vibration;

### Notice

**For special installation requirements, consult Trane's technical support or after-sales department.**

Requirements for installation foundation:

1. The foundation may be a steel frame structure, such as channel steel.
2. The foundation may be a reinforced concrete structure.
3. The foundation shall be completely horizontal to ensure uniform contact of the unit.
4. The foundation shall be strong enough to support the unit weight.
5. A drain ditch shall be arranged around the foundation to prevent water accumulation around the unit.
6. There shall be 8-10mm thick shock pad between the foundation and the unit.

## Diagram for Bolt Fixing Position

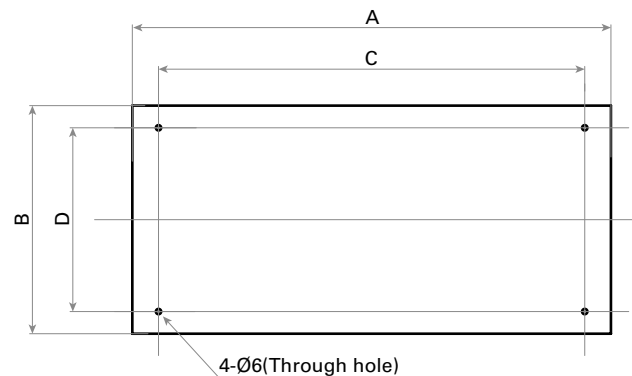

Model	065	130-double-Y structure	130-single-Y structure
<b>Dimension</b>			
A	2145	2145	2400
B	951	1500	880
C	2038	2038	2293
D	927	1476	837

## Requirements for Installation Space

During installation, problems such as drainage, ventilation and operating space shall be considered, and the normal operation, maintenance and repair of the unit shall be ensured. Installation should meet the minimum space requirements, otherwise the unit may have the problems such as performance degradation, noise increase, operation failure and maintenance difficulties.

### Notice

**If the requirements for installation space are not met, consult Trane's technical support or after-sales department.**



## Unit Installation

### Diagrams for Unit Installation Foundation and Space

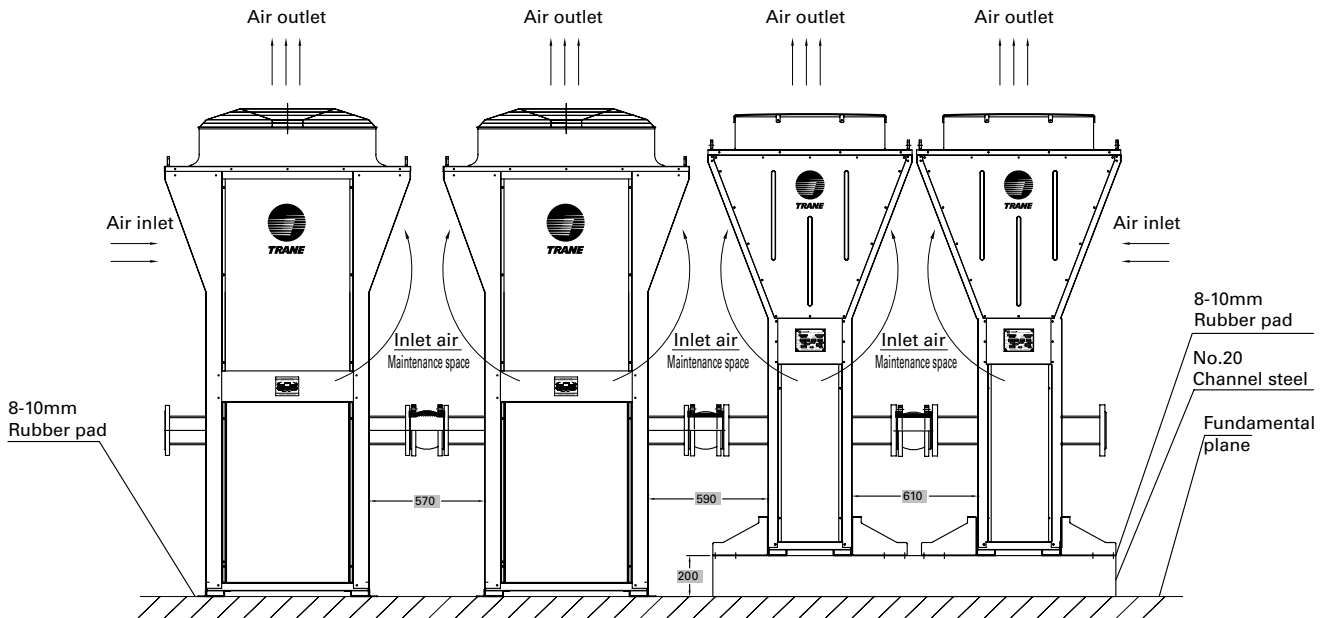

Note :

1. Make sure there are 1.2 meters space around units at least.
2. Make sure there is more than two meters of ventilation space on the top of the unit.
3. Make sure the air inlet of the unit shall meet the unit requirement.
4. Make sure Air inlet temperature of the unit shall be within the reasonable range specified by the unit.

### Diagram for Single-module Combination (Direct Return Connection)

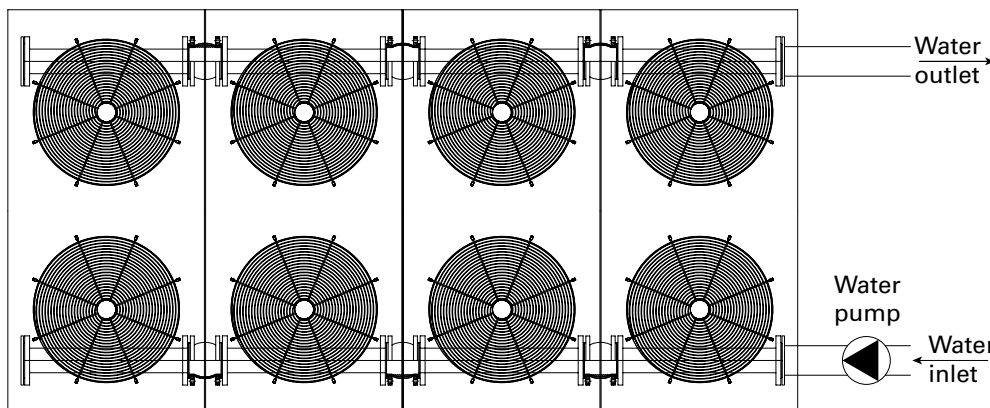

Note: CXAJ/CGAJ065 single-module combination includes at most 4 sets in the direct return connection, and CXAJ/CGAJ130 single-module combination includes at most 2 sets in the direct return connection.



## Unit Installation

### Diagram for Single-module Combination (Reversed Return Connection)(Recommended)

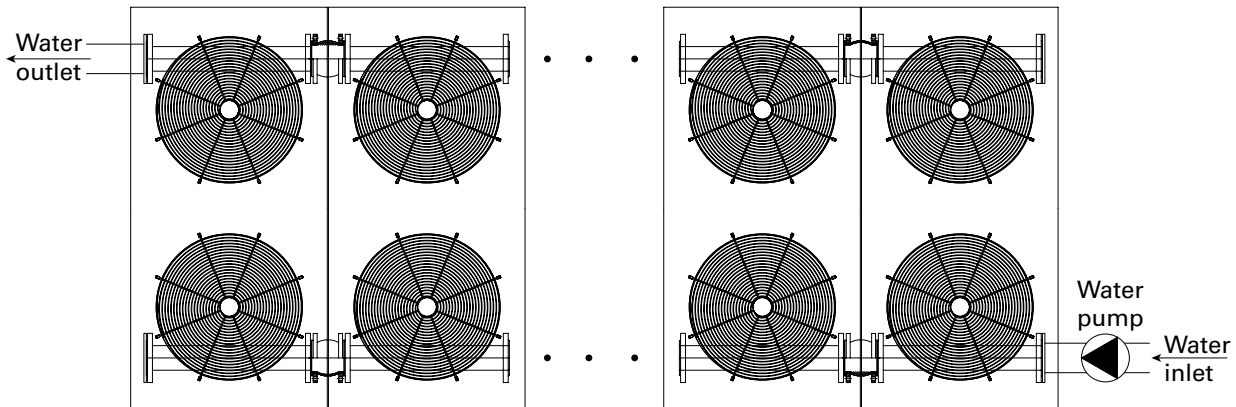

Note: CXAJ/CGAJ065 single-module combination includes at most 8 sets in the reversed return connection, and CXAJ/CGAJ130 single-module combination includes at most 4 sets in the reversed return connection.

### Diagram for Multi-module Combination (Reversed Return Connection) (Recommended)

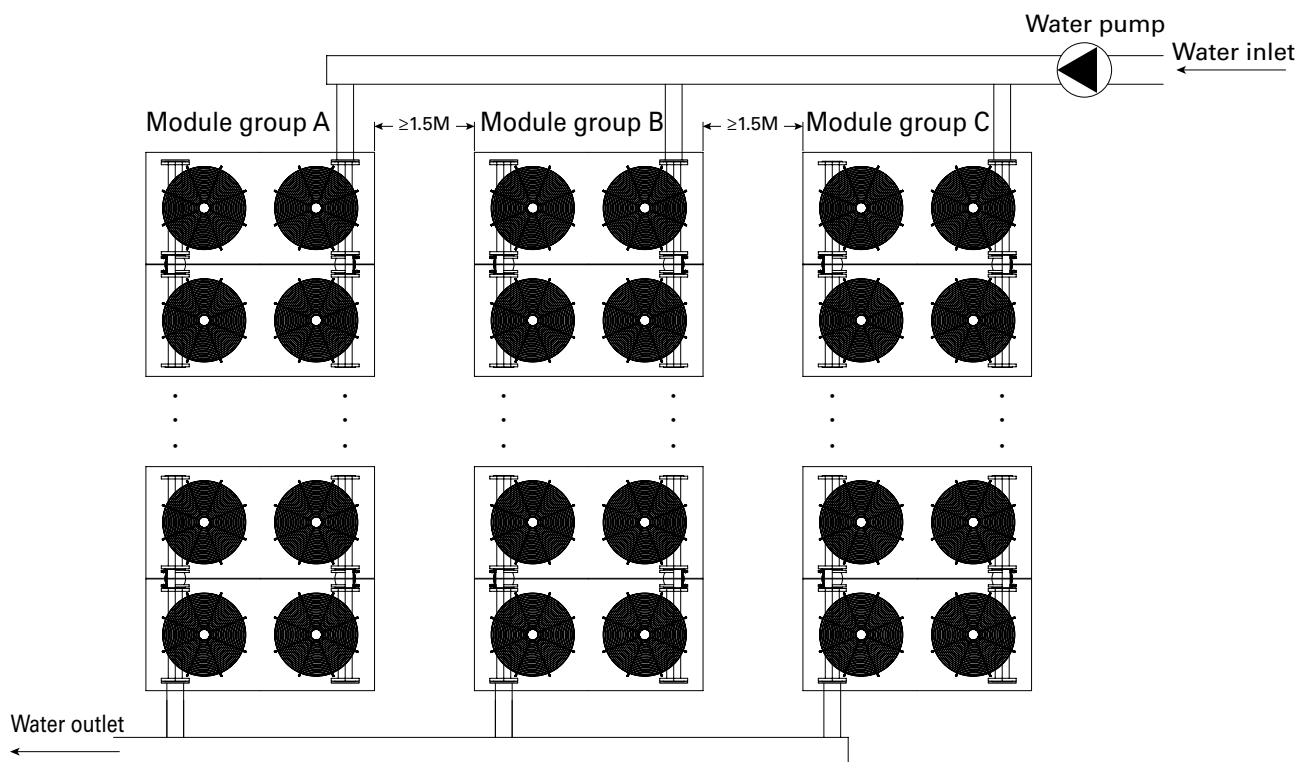

Note: CXAJ/CGAJ065 multi-module combination includes at most 8 sets per group, CXAJ/CGAJ130 multi-module combination includes at most 4 sets per group, and no direct return connection is allowed.



## Unit Installation

### Installation of Water System

#### Requirements for Pipeline Prefabrication

1. The diameter of the inlet and outlet water pipes for the water system shall not be smaller than that of the unit joints (DN125);
2. The connections between the pipeline and the water pump and between the pipeline and the air conditioner must be flexible pipes, which shall not be forcibly connected to reduce the vibration transmission;
3. The pipes shall be connected through welding flanges, and the secondary galvanization or antiseptic treatment shall be performed on the welding seam and the surface of the heat affected area;

The blind flange shall be installed for the unit at the end, as shown below.

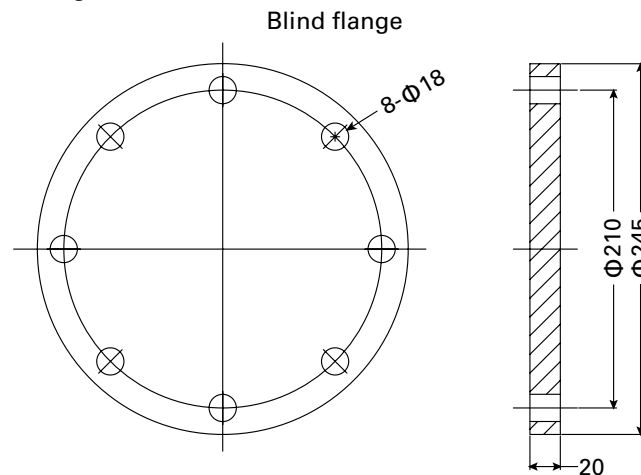

#### Requirements for Pipe Installation

All water pipes shall be connected in accordance with the relevant regulations and comply with the local plumbing regulations and rules. Refer to the schematic diagram for the installation of typical accessories for the water system. Please strictly comply with the following installation requirements for the water system pipeline, otherwise it will affect the normal operation of the unit, or even cause malfunction or damage to the unit.

1. Water flow rate of air conditioning unit: the water flow rate of the water system must be firstly designed in a standard way by professional designers, so that the flow rate of water flowing through the water side heat exchanger of the air conditioning unit is matched with the cooling capacity of the unit. Otherwise, the heat exchange easily gets worse, affecting the air conditioning effect or even causing alarm and shutdown. When the terminal fan coils are fully turned off or a single fan coil is turned on, the air conditioner is turned on for steady operation for a period of time, and the temperature difference between the inlet water and the outlet water shall be controlled to 4 and 6 degrees Celsius. If this requirement is not met, the water system resistance or pump head shall be adjusted until the requirement is met.
2. Water volume: the water volume of the water system will affect the start/stop times of the compressor for the air conditioning unit and cause the cold-state ventilation during the defrosting process of air-cooled fins in the heating mode. It is required that the whole water system shall be provided with 10 liters/Kw water. If this requirement cannot be met, an energy storage tank shall be installed in order to meet this requirement.
3. Pipe size: The water pipe size must be determined through the water system design to ensure the water flow of the unit.
4. Terminal water flow rate: the water flow rate of the terminal product on the air side of the water system must be firstly designed by professional designers in a standard way, so that the flow rate of water flowing through each water coil on the air side is matched with the cooling capacity of the terminal product on the air side.
5. Inlet and outlet pipes: the pipes must be supported independently and shall not be supported on the unit. In order to avoid damage to the unit, the system water pipes shall not be installed in reverse. The inlet pipe of the unit



## Unit Installation

---

must be connected to the water inlet joint marked with "water inlet" ; the outlet pipe must be connected to the water outlet joint marked with "water outlet"

6. Anti-vibration hose: the inlet and outlet pipes of the unit must be connected with anti-vibration hoses to avoid long-distance noise transfer. If there is an external water pump, the anti-vibration hoses must be installed at the inlet and outlet pipes of the pump, and the outlet water of the pump shall flow to the air conditioning unit.
7. Water pressure gauge: the pressure gauge and the cut-off valve shall be installed at the inlet of the inlet pipe and the outlet of the outlet pipe for the air conditioning unit. If there is an external pump, the pressure gauge and the cut-off valve shall be installed at the water inlet of the pump in order to understand the water system resistance and pump head consumption of the unit, facilitate the monitoring and adjustment of water flow and cut off the water flow during maintenance.
8. Water filter: Y-shaped water filter must be installed within 50cm of the water inlet pipe of the air conditioning unit to prevent impurities in the pipe from blocking the water-side heat exchanger and causing unit failure. The number of meshes for the filter shall be 40. If there is an external pump, the water filter must also be installed at the water inlet of the pump. The number of meshes for the filter shall be 40 to avoid pump damage.
9. Water flow switch: the water flow switch must be installed at the water outlet of the unit. The straight distance at least 5 times of the pipe diameter shall be reserved at the front and rear ends. If there is an internal water flow switch, the switch will not be installed again.
10. Exhaust valve: the automatic exhaust valve shall be arranged at the top of the main outlet pipeline and the main return pipeline for the water system to exhaust the air in the cold water system, ensure that the water flow of the unit meets the requirements of the product and avoid cavitation noise and damage to the water pump. The exhaust valve of the water system is generally installed at the top of the junction between the vertical pipe and the horizontal pipe for the water system and is 0.5 meters higher than the upper horizontal plane of the fan coil at the highest position of the water system. When the exhaust valve is installed in the horizontal manifold, it shall be installed on a pipe section with 2 to 3 specifications larger than the manifold, and straight pipes at least 4 times the pipe diameter are arranged on both sides, so that water and air are discharged through the exhaust valve after separation.
11. Leakage prevention of exhaust valve: for the exhaust device, it is necessary to consider the cut-off measures for easy replacement when it is damaged or fails. All exhaust pipes shall be connected to the sink and the floor drain in order to discharge water and prevent the exhaust device from damage, failure or leakage to destroy the household environment.
12. Expansion tank: the expansion tank shall be arranged in the water system to adapt to the water pressure fluctuation caused by the water temperature change in the water supply system. The gravity expansion tank shall be installed on the top of the main water return riser of the pump for the unit, the make-up pipe is connected to the water return pipe of the pump, and the overflow device is provided; or the pressure type expansion tanks installed on the main water return pipe, and the automatic make-up valve and the automatic pressure relief valve are provided. The size of expansion tank can be selected by 3% of the total water volume of the water system for the air conditioning unit.
13. Operating water pressure: the water pressure of the water side heat exchanger for the air conditioning unit shall not exceed 0.5MPa(i.e. the maximum operating pressure), so as to avoid damage to the parts on the cold water side of the unit.
14. Two-way/three-way valve installation: the two-way valve or three-way solenoid valve shall be installed at the outlet of the fan coil to avoid complaints of waterway vibration and noise.
15. Two-way valve installation: the water system cannot completely use two-way solenoid valves. If the two-way valve is used, it can be mixed with the three-way valve. The quantity ratio can be 1/3 of two-way valves and 2/3 of three-way valves. The two-way valve can be installed on the fan coil near the air conditioning unit, and the three-way valve can be installed in the far end. If only two-way valves are installed, the pressure differential bypass valve can be added between the main water supply and return pipes of the air conditioning unit at the same time.
16. Differential pressure bypass valve: if the differential pressure bypass valve is used in the system, it is necessary to ensure that the short circulation loop of the bypass valve contains an energy storage tank and also meets the water volume requirements, that is, 10 liters of water per kilowatt of cooling capacity. When all fan coils are turned off and the two-way valve is closed, the opening size of the differential pressure bypass valve and the bypass valve flow must ensure that the inlet and outlet water temperature difference is controlled between 4-6 °C to ensure the water flow requirements of the unit.
17. Parallel units: when two or more units are used in parallel, it is recommended that a manifold should be installed on the main water return pipe to ensure the return water supply and correct flow distribution of the



## Unit Installation

---

- unit. When water chilling units with different cooling capacities are connected in parallel in a water system (not recommended), a hydraulic balance valve must be installed to ensure different water flow requirements of the water-side heat exchangers for the water chilling units with different cooling capacities. It is recommended that the water pipes for the parallel water chilling units be installed in the same way as the reversed return pipes.
18. Check valve: if the unit is located at the lower position of the whole water system, the check valve shall be installed on the outlet pipe of the unit to prevent the impact of water hammer on the water system parts of the unit.
  19. Bypass pipeline: the bypass pipelines and the bypass valves must be installed at the inlet and outlet of the water system for the unit. All external water supply pipeline systems shall be thoroughly flushed prior to the final connection of the unit. It is strictly prohibited to mix sundries in the water system, otherwise serious consequences may be caused. The bypass valves shall be used to bypass the unit and the terminal heat exchanger for flushing. After flushing, the bypass valves shall be closed, and the drain valves on the inlet and outlet pipes shall be opened.
  20. Drainage: drainage pipes and drainage valves shall be installed at the lowest point of the water system and the lower part of the equipment to be drained, and the floor drain or funnel shall be connected to facilitate the cleaning and maintenance of the water system.
  21. Thermal insulation: the chilled water pipe shall be thermally insulated to prevent water dripping due to heat loss and pipe surface condensation. The exterior of the water-side parts in the water system in contact with the air shall be thermally insulated to prevent water dripping due to condensation. The water system parts that may be damaged by freezing in winter shall be thermally insulated, and the thickness of the insulation layer shall meet the requirement that freezing is not caused at the local minimum ambient temperature. Especially for the make-up system pipeline of the gravity expansion tank or the automatic make-up valve pipeline of the pressure expansion tank in the water system, sufficient insulation measures shall be considered or the pipeline shall be installed in a suitable place indoors to avoid freezing damage.
  22. Anti-freezing: when the ambient temperature is low and the unit is not used for a long time, please drain off water in the unit to avoid freezing damage to the water-side parts of the unit. If the water is not drained, do not cut off the power supply of the unit, so that the unit can operate automatically against freezing. During the period, if there is a fault alarm that cannot be repaired within a short time, the water must be drained. In winter, the water in the system of the single-chiller unit must be drained off to prevent the water in the system from being frozen to damage water pipelines, pumps, heat exchangers and other main components of the unit. Other antifreezing methods are not recommended. The unit damage caused by the non-recommended antifreezing methods are not within the scope of warranty.
  23. Modular unit: Main leaving water temperature sensor (TH12) : if the units are installed in modular mode, a place for installing the temperature sensor must be reserved on the main outlet pipe of the water system, so as to install the outlet water temperature sensor of the system.
  24. Pressure maintaining and leakage detection: after the installation and connection of water system pipelines, the water pressure test shall be carried out. The accuracy of the pressure gauge shall be greater than 0.01MPa. The test pressure shall be 1.5 times the operating pressure. If the pressure is maintained together with the heat exchanger of the unit, the maximum pressure shall not exceed 0.5MPa (i.e. the maximum operating pressure), so as to avoid damaging the parts on the cold water side of the unit. When water is filled in the water system, the exhaust valve must be opened and closed after the air is exhausted and water is filled. If any leak is found during the pressure maintaining process, repair it immediately and repeat the pressure maintaining test.
  25. Cleaning: the water system must be cleaned before unit starting and commissioning. During cleaning, the water system must be separated from the unit and cleaned separately, and it can be connected to the unit for starting and commissioning only after there are no impurities in the water system. In the process of unit operation, the Y-shaped water filter shall be cleaned regularly depending on the cleanliness of the water system, so as to avoid the situations that the air conditioning effect is poor due to too small water flow, even the water flow alarm of the unit occurs and the outlet water antifreezing alarm lamp has a failure to cause shutdown.
  26. Control wire of external pump: the external pump shall be equipped with a starter, and its control wire shall be connected to the pump output port of the unit and link-controlled by the unit to ensure the automatic protection function of the unit.

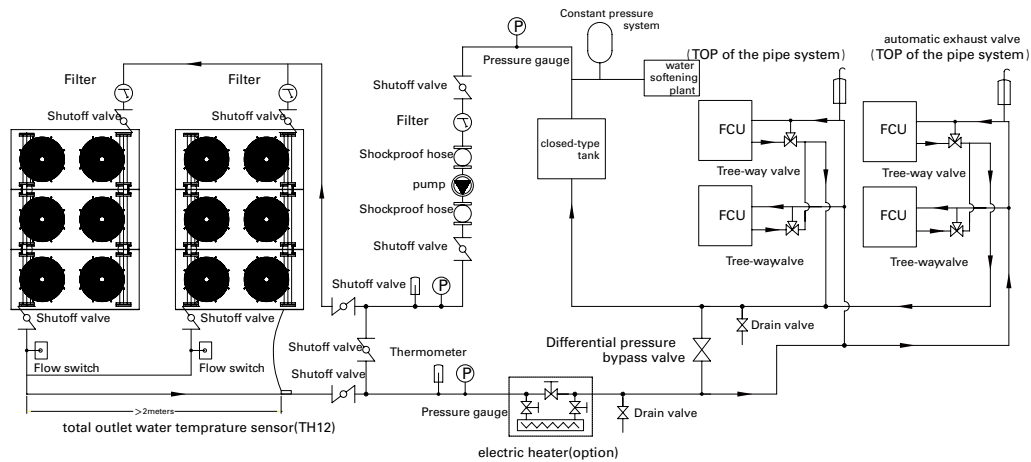

- Note:**
- 1) Each branch needs to install a water flow switch, which is connected to the A0 host chiller in series.
  - 2) The total outlet water temperature sensor (TH12) must be connected to the A0 host chiller.
  - 3) The unit must be connected to the closed water system, the water quality must meet the water treatment requirements (P18) of this book, and the secondary heat transfer must be carried out when the water quality does not meet the requirements.
  - 4) The secondary heat transfer must be carried out when the chillers is applied for domestic hot water.

**Figure 1. Installation Diagram for Water System**

### ⚠ Notices

1. The automatic exhaust valve shall be installed at the highest position of the pipe, and the water pipe shall be expanded at the installation position.
2. The drain valve shall be installed at the bottom of the pipe to facilitate drainage.
3. The reversed return piping is beneficial to even distribution of water flow.
4. The two-way valve shall be installed on the fan coil close to the main inlet and outlet pipes to avoid short pass.
5. The normal operating water volume can ensure normal defrosting in winter (ensure water volume exceeds 10L/KW).
6. The system must be equipped with the automatic make-up valve and the automatic exhaust valve at the highest point.
7. The three-way valve shall be installed on any fan coil at the farthest end except the largest fan coil to

ensure that the water flow does not reach low alarm limit.

### ⚠ Warning

**All external water supply piping systems shall be thoroughly flushed prior to the connection of the unit to the external water piping systems. It is strictly prohibited to mix impurities in the piping system, otherwise the company will not be responsible for any consequences caused thereby.**

### Instructions on Unit Drainage

1. Face to the electric cabinet, and remove the metal plates on the inlet and outlet pipe surface, as shown below on the left;
2. Draining water position at the bottom of the shell with a wrench to drain water. See the picture below on the right.

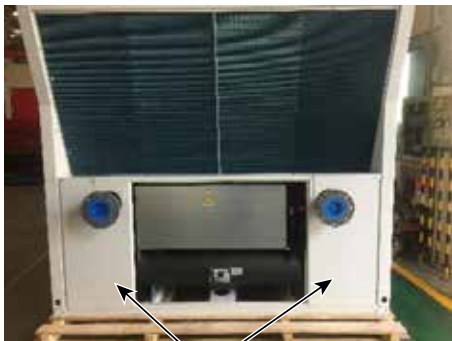

Remove two metal plates



Unscrew the plugs on both sides



## Unit Installation

### Installation of Main Outlet Water Temperature Probe

1. The main outlet water temperature probe shall be placed at 2m or more away from the outlet to ensure that the outlet water temperature is evenly mixed.
2. The main outlet water temperature probe sleeve shall be 9.52mm copper pipe, shall be inserted into the water pipe at the depth of 2/3 of the diameter of the water pipe, and shall be installed above the water pipe.
3. After the insertion of the main outlet water temperature probe, the sleeve shall be filled with heat transfer silicone and covered with waterproof materials to prevent water from entering the sleeve.

### Auxiliary Electric Heating of Waterway (installed by user)

When the unit heats, if the outlet water temperature is less than the set value of 10°C, the electric heating will be turned on; when the outlet water temperature is more than or equal to the set value minus 6°C, the electric heating will be turned off.

### Water Treatment Requirements

Filth, dirt, grease and other impurities will have an adverse impact on the heat exchange effect of heat exchanger and the unit performance. Foreign substances in the chilled water will increase the water pressure drop of the heat exchanger, reduce the water flow and cause the blockage or mechanical damage of the heat exchanger.

Please test in strict accordance with the water quality requirements of the unit water system to ensure that the water quality of the water system meets the requirements in the table.

Item	Unit	Allowable Value	Tendency	
			Corrosion	Scaling
PH (25°C)		7.5-8.0	○	
SO4--	ppm	< 100	○	
HCO3-/SO4--	ppm	> 1.0	○	
Cl-	ppm	< 50	○	
PO4	ppm	< 2.0	○	
NH3	ppm	< 0.5	○	
Free Chlorine	ppm	< 0.5	○	
Fe+++	ppm	< 0.5	○	
Mn+++	ppm	< 0.05	○	
CO2	ppm	< 10	○	
H2S	ppm	< 50	○	
Temperature	°C	< 65		○
Oxygen content	ppm	< 0.1	○	
Total hardness	dH	4.8-8.5		○

### ⚠ Notices

1. Before and during the installation of the unit, the user shall regularly test the water quality to ensure that the water quality meets the requirements in the above table. Once the water quality exceeds the allowable value for a long time, the heat exchanger may cause corrosion, leakage and serious scaling;
2. The items with corrosion tendency indicate that if the water quality exceeds the allowable value for a long time, it may cause the corrosion and leakage of heat exchange tubes, which will prevent the normal operation of the unit and affect its normal use;
3. The items with scaling tendency indicate that if the water quality exceeds the allowable value for a long time, it may cause the severe scaling in the heat exchanger, which will affect heat transfer and directly decrease the cooling(heating) effect of the unit;
4. Losses caused by the water quality problems of users shall be borne by users.



# Electrical Installation

## Safety Precautions

The following contents are related to safety, please strictly follow them!

### Warnings

1. All wires and grounds shall conform to the local electrical regulations.
2. Refer to the electrical parameters and the wiring diagram to complete layout and wiring and ensure firm wiring.
3. Provide the independent power supply with a current circuit breaker matched with the working voltage of the unit. Do not share power supply with other electrical products to avoid overload risk.
4. The wire shall not be in contact with sharp metal plate edges, screw tips, copper pipes, compressors, motors or other moving parts to avoid damage to the wire to cause danger.
5. The manufacturer will not be responsible for any problems caused by unauthorized changes to the internal wiring.
6. After the completion of wiring, fix with wire clips to prevent wire damage caused by falling and collision with other parts to cause danger.
7. Separate unit wiring by strong and weak current, so as not to affect the communication and operation of the unit.
8. All units shall be safely grounded. Improper grounding may cause electric shock. Please ensure that the earth wire is firmly connected to the grounding terminal and grounding electrode of the unit.
9. There is strong current in the electric cabinet. Before the completion of electrical wiring for the unit, do not power on to avoid causing casualties.
10. Before cutting off the power supply of the unit at any time, do not touch the control components and terminal components to avoid electric shock injury.
11. Only connect the terminals with copper wires to avoid corrosion or overheating.
12. Refer to the circuit diagram of the unit for the connection of water flow switch and water pump wires.

## Electrical Wiring

1. Connect the power line to the main terminal (TB) of the unit distribution box.
2. Connect the PCB board of chiller and the modular or unit controller with the wires.
3. If the unit is not equipped with a pump, connect the power line of the cold water pump to the corresponding terminal of the cold water pump.
4. Ground the unit, the cold pump motor (unit without pump) and all devices to be grounded.
5. If the electric heater is provided, connect the power line and the control line to the terminal of the electric heater.
6. Refer to the circuit diagram for specific wiring.

### Warnings

1. **The installer shall provide the unit with a power supply with correct voltage and a suitable circuit breaker, and the supply voltage shall fluctuate within the range of  $\pm 10\%$  of the standard value.**
2. **Before the completion of electrical wiring, do not power on to avoid causing casualties.**



## Electrical Installation

### Electrical Specification

Please refer to the following table for the minimum current, the fuse specification and the electrical specification of motor.

Type	Model	Power Supply (V/Hz/ph)	Max. current of No.1 compressor MOC (A)	Max. current of No.2 compressor MOC (A)	Max. current of No.3 compressor MOC (A)	Max. current of No.4 compressor MOC (A)	Rated current of No.1 fan FLA (A)	Rated current of No.2 fan FLA (A)	Max. operating current of unit MOC (A)	Recommended fuse specification REC(A)	Recommended circuit breaker specification In (A)	Min. specification of the power supply copper core wire diameter mm <sup>2</sup>
Standard	CX(G)AJ0655	380/50/3	24	24			2.1	2.1	55	91	69	16
	CX(G)AJ1305	380/50/3	56	56			3.96	3.96	120	207	154	50
High Efficiency	CX(G)AJ065	380/50/3	24	24			2.1	2.1	55	91	69	16
	CX(G)AJ130	380/50/3	24	24	24	24	2.1	2.1	98.2	143	133	50

### Notice

The unit shall be energized for inspection before starting. If the green light is on, it will indicate that the unit is normal; if the red light is on, it will indicate that the phases are reverse and any two phases shall be exchanged in the three-phase power supply. If the yellow light is on, it will indicate that the power supply is lack of phase and shall be powered off for inspection. In the case of reverse phase or lack of phase, the unit will be automatically prohibited from running or starting. The phase loss protection is only for the input power supply of the unit.



# Electrical Circuit Diagram

CX(G)AJ065

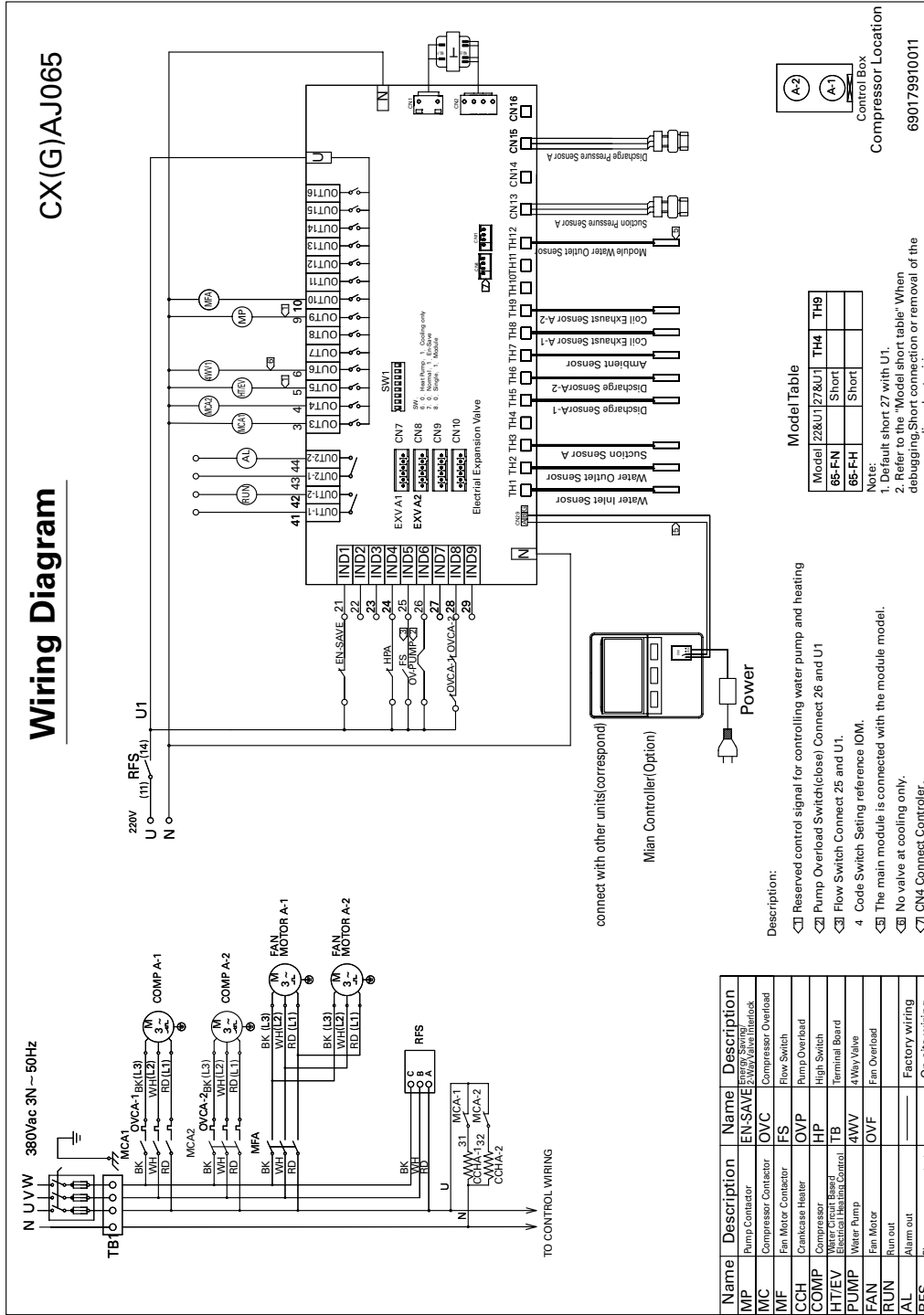



Electrical Installation

CX(G)AJ130 N

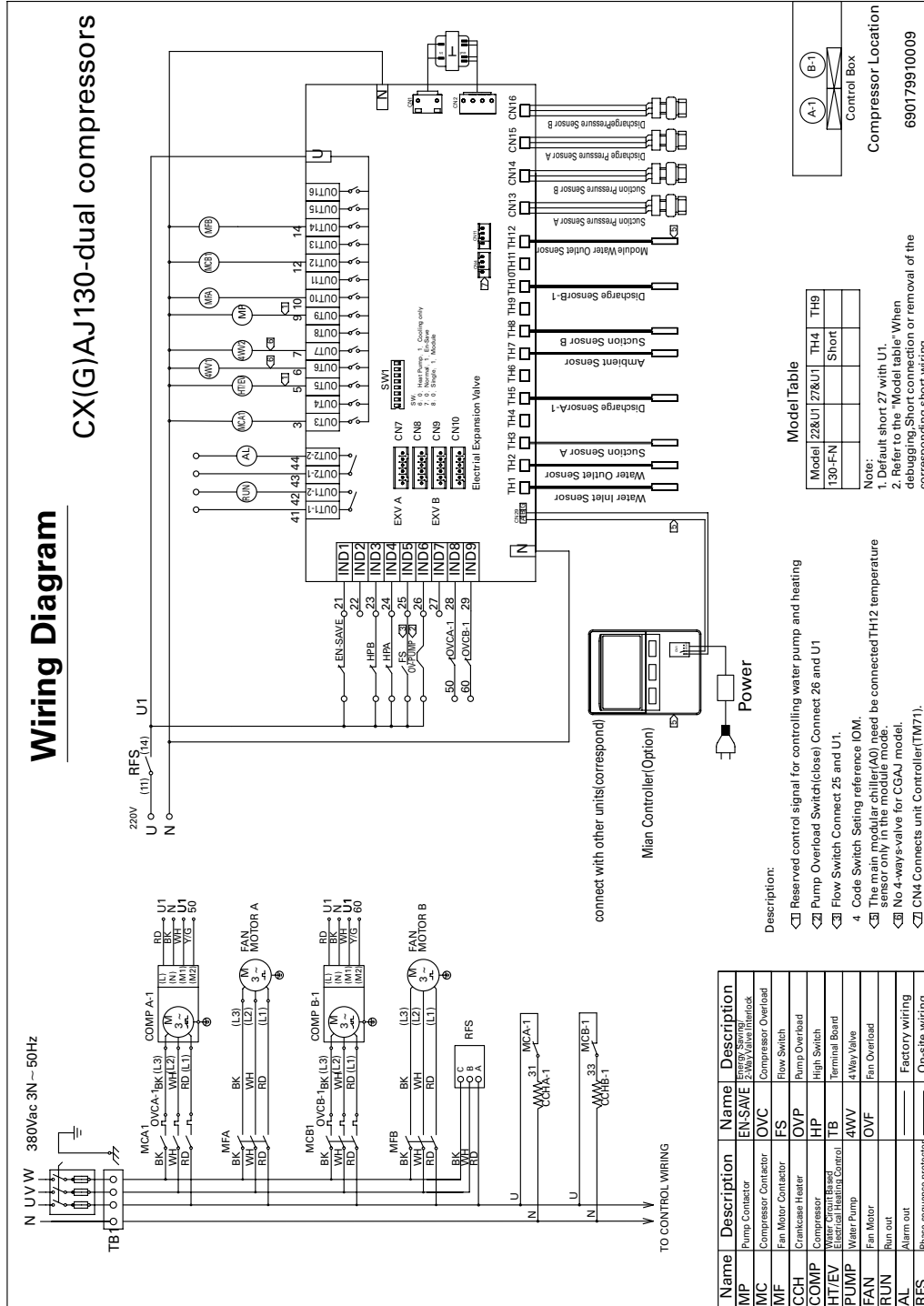





## Pilot Run

### Inspection before Start-up

1. Inspect the connection of all wires. All electrical contacts shall be kept clean and locked.
2. Inspect whether the supply voltage of the unit is normal.
3. Fill the cold water loop with water. Keep the exhaust valve of the system open during filling, and close the exhaust valve after filling.
4. Short-circuit the flow switch to test the water system.
5. Switch on the main power supply, and press the switch button on the control panel to start the unit. At this time, the water pump should be started, and the water is circulated in the cold water system. Inspect for leakage at all pipe connections.
6. Adjust the water flow in the cold water loop, and inspect the external water pressure or evaporator pressure drop of the unit, and the differ water temperature of inlet and outlet is about 5°C .
7. Stop the pump operation. Turn off all power supplies.
8. Connect the flow switch to the contact on the terminal board inside the control box.

### Voltage Range

The unit power supply must conform to the operating power supply indicated on the unit nameplate. The supply voltage and the voltage imbalance between phases must be within the following range. Measure the voltage between phases. Its reading must be within the allowable voltage tolerance ( $\pm 10\%$ ) shown on the unit nameplate. If the voltage between any two phases is not within this tolerance, the power company shall be notified for improvement before the unit running. Improper voltage will result in abnormal control function and shorten the life of various electrical components and compressor motor.

### Voltage Unbalance

Large voltage unbalance between phases in the three-phase power system will cause motor overheating to result in motor failure. The maximum allowable unbalanced voltage is 2%. The voltage unbalance is defined as follows:

$$\text{Voltage unbalance \%} = \frac{100 \times |V_a - V_d|}{V_a} \%$$

Wherein

$$V_a = (V_1 + V_2 + V_3) / 3 \text{ (average voltage)}$$

$V_1, V_2, V_3$  = line-to-line voltage

$V_d$  = maximum line-to-line voltage deviating from  $V_a$

### Water Flow

The cold water flow through the unit must be between the upper and lower limits listed in [Table 1](#). If the flow rate of cold water entering into the evaporator is lower than the lower limit, it will cause the discontinuity of water flow, reduce the heat transfer effect and cause the expansion valve out of control or abnormal low-pressure tripping. On the contrary, if the water flow rate is higher than the upper limit, the parts inside the evaporator will be eroded.

**Table 1. Water Flow of Unit**

(Unit: m<sup>3</sup>/h)

Model	Lower flow limit	Rated flow	Upper flower limit	Pipe size
CX(G)AJ065	6.71	11.2	15.65	DN125
CX(G)AJ130	13.4	22.4	31.6	DN125

**⚠ Notice:** When the pump runs, adjust the water flow to 50% of the rated flow, disconnect the flow switch contact from the circuit board, and verify that the switch contact is open at this time by using the ohmmeter.

### Water Pressure Drop

By measuring the water pressure difference between the inlet end and the outlet end of the unit (including the water pump), the unit head at this flow rate can be obtained. The unit head should be basically as shown in the "head" curve. For the design of the piping system for the standard model with a water pump, refer to the water pressure drop curve. For the model without a water pump (the water pump is installed outside the unit), the internal water pressure drop of the unit should be basically as shown in the curve of "water pressure drop of unit" . For the design of the piping system for the model without a water pump, refer to [Figure 2](#).

**Figure 2. Water Pressure Drop Characteristic Curve Charts**

CX(G)AJ065

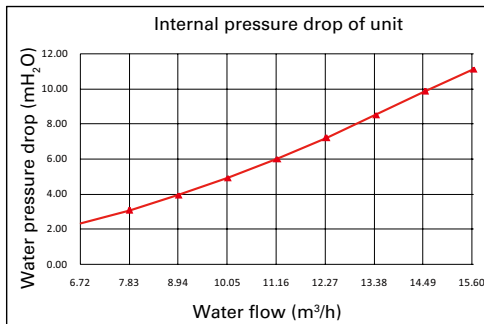

CX(G)AJ130

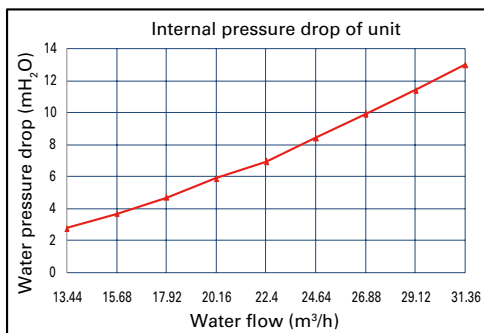

## Unit Setting

Please set the functions and operating parameters of the unit according to the following methods before starting the unit or during commissioning. The unit functions are mainly defined by jumpers, dial switches and system bits. Incorrect settings may cause the unit to operate incorrectly or even fail to run!

### Jumper Setting

Jumper JP1 is used for software version control. Unplug JP1 to download software; short-circuit JP1, then the system will work properly.

### Setting of Dial Switch

SW1 function definition

Bit1	Bit2	Bit3	Bit4	Bit5	Bit6	Bit7	Bit8
Modular IP					type	EnSave	Control

Bits 1-15 of the switch are used for encoding the modular control address.

**Notice:** For the modular unit of of this model, dial 00.

SW1: setting of modular control address

No.	SW1 switch				
	1	2	3	4	5
0(modular control display A0)	OFF	OFF	OFF	OFF	OFF
1(modular control display A1)	ON	OFF	OFF	OFF	OFF
2(modular control display A2)	OFF	ON	OFF	OFF	OFF
3(modular control display A3)	ON	ON	OFF	OFF	OFF
4(modular control display A4)	OFF	OFF	ON	OFF	OFF
5(modular control display A5)	ON	OFF	ON	OFF	OFF
6(modular control display A6)	OFF	ON	ON	OFF	OFF
7(modular control display A7)	ON	ON	ON	OFF	OFF
8(modular control display A8)	OFF	OFF	OFF	ON	OFF
9(modular control display A9)	ON	OFF	OFF	ON	OFF
10(modular control display A10)	OFF	ON	OFF	ON	OFF
11(modular control display A11)	ON	ON	OFF	ON	OFF
12(modular control display A12)	OFF	OFF	ON	ON	OFF
13(modular control display A13)	ON	OFF	ON	ON	OFF
14(modular control display A14)	OFF	ON	ON	ON	OFF
15(modular control display A15)	ON	ON	ON	ON	OFF
16(modular control display A16)	OFF	OFF	OFF	OFF	ON
17(modular control display A17)	ON	OFF	OFF	OFF	ON
18(modular control display A18)	OFF	ON	OFF	OFF	ON
19(modular control display A19)	ON	ON	OFF	OFF	ON
20(modular control display A20)	OFF	OFF	ON	OFF	ON
21(modular control display A21)	ON	OFF	ON	OFF	ON
22(modular control display A22)	OFF	ON	ON	OFF	ON
23(modular control display A23)	ON	ON	ON	OFF	ON
24(modular control display A24)	OFF	OFF	OFF	ON	ON

Bits 6-8 of the switch are used for setting the unit functions. See the following table.

6	7	8
Type	En-Save	Control

**Type:**

- 0 Heat pump
- 1 Single-cooling

**EnSave:**

- 0 Conventional
- 1 Two-way valve interlocking

Note: this function is invalid when "module control" is selected.

**Control:**

- 0 Single-machine control
- 1 Module control



## Pilot Run

---

### Parameter Setting

The unit protection parameters and operation parameters can be set by the line controller in the shutdown state. The set values for default parameters are shown in the table below.

Code on unit controller/ modular controller	Parameter setting	Max.	Min.	Adjustment precision	Default setting
016	Set temperature of cooling condition	15°C	5°C	1°C	7°C
017	Set temperature of heating condition	50°C	30°C	1°C	45°C
022	Anti-freezing temperature in winter	5°C	1°C	1°C	3°C
001	Defrosting interval	90min	30min	1min	45min
002	Min. defrosting time	8min	1min	1min	3min
	Password range	75	50	-	50

Note: enter the password '66' through the modular controller to set.



# Unit Operation

## Startup Step

Power on the unit, press MODE on the control panel to select cooling or heating, and then press OK on the control panel to start the unit. Operate the unit for more than 30 minutes. When the system runs stably, check the following items to ensure the normal operation of the unit:

1. Check whether the inlet and outlet water temperature difference and water pressure readings of the unit are stable and within the normal range.
2. Test the high and low pressures of the unit. In normal operation, the low pressure shall be 85-145psig (0.586-1.0MP), and the high pressure shall be 2.290-500psig (2.0-3.45MPa).
3. Check the current reading of the compressor.
4. Check the power supply.
5. Check whether there is any moisture in the sight glass (if have) of the liquid pipe.
6. Measure the system superheat.  
In ARI conditions (inlet water temperature of 12.2 °C , inlet water temperature of 6.7 °C and ambient temperature 35 °C ), the normal system superheat of each loop shall be 5-8 °C . If the superheat measured on any loop is not within this range, the superheat setting of the expansion valve shall be adjusted to obtain an appropriate reading. After adjusting the expansion valve each time, wait 15 to 30 minutes for the stabilization of new set value.
7. Measure the system subcooling degree.  
In ARI conditions, the normal system subcooling degree of each loop shall be 5-10 °C . If the subcooling degree measured on any loop is not within this range, make necessary adjustment after checking the superheat of the loop. If superheat is normal but subcooling is abnormal, please contact professional maintenance personnel.
8. If the refrigerant is judged to be insufficient by operating pressure, sight glass, superheat and subcooling degree, the leakage point shall be found. After maintenance, the refrigerant shall be filled according to the parameters of the nameplate. After start-up, the high and low pressures shall be within the normal range.
9. Make sure that all thermometer bulbs are installed in the correct position. The capillary tubes of the thermometer bulbs must be firmly fixed to avoid vibration and wear.

## Long-time Shutdown

If the system is not in use for a long time, the following steps shall be implemented before shutdown:

1. Check whether there is any leakage in the refrigerant pipe. If any, be sure to repair it.
2. Drain off the circulating water in the system, open the drain outlet in the water supply and return loops, disassemble the side panel of the unit, and open the drain outlet at the bottom of the shell to ensure that the circulating water is drained off.
3. Turn off the power switches for the unit and the water pump.

### Warnings

**1. Power off after the circulating water in the system is drained off, otherwise the unit and the pump will be damaged.**

**2. When there is water in the system, the unit and the water pump must be powered on, otherwise the unit and the water pipeline will be frozen.**

## System Start-up after Long-time Shutdown

1. Open the valves for the water return and supply pipelines, and fill fresh water into the cold water pipeline. Be sure to exhaust when filling with water. After the system is filled with water, close the exhaust valve.
2. Turn on the power switch of the unit, and test whether there is an alarm.
3. Press the start button on the control panel to start the unit.
4. After starting all compressors of the unit, only turn on the terminal compressor to check whether the inlet and outlet water temperature difference of the water system is 4-6 °C . Otherwise, the waterway system shall be inspected and modified.

## System Protection

### Low Pressure Protection (LP1, LP2)

The unit is protected by a low pressure switch. When the operating pressure is lower than the set value, the compressor will be stopped and shall be manually reset.



## Unit Operation

---

### High Pressure Protection (HP1,HP2)

The unit is protected by a high pressure switch. When the high pressure is higher than the set value, the compressor will be stopped and shall be manually reset.

### Winter Antifreezing Function

When the unit is in standby state in winter and the water temperature is lower than the set winter antifreezing temperature, the unit will automatically start the antifreezing function and display “AP”. Therefore, when the unit is in standby state in winter, it is forbidden to cut off the power supply.

If the pump is overloaded during antifreezing operation, immediately stop the pump operation (close all peripheral devices), quit the antifreezing protection and display the pump overload fault alarm on the controller. At this time, the standby pump system shall be started to ensure the normal operation of waterways.

### Antifreezing Protection of Heat Exchanger

When the outlet water temperature is lower than 3 °C in the cooling state, the compressor will be turned off, and the water pump will continue to run, and “E3” will be displayed.

When the outlet water temperature is less than or equal to “antifreezing inlet water temperature (coil/shell)” or the water return temperature minus the outlet water temperature is more than 10°C in the cooling mode, the compressor will be turned off, the water loop electric heating will be started, the water pump will continue to run, and the code “E3” will be displayed on the line controller.

### Motor Overload Protection

- Overload and overheating protection of compressor motor.
- Overload protection of pump motor.
- Overheating protection of fan motor.

### Temperature Probe Protection

When the temperature probe fails, the system will give an alarm and stop. All alarm protection is manually reset. Firstly troubleshoot, press “Reset” or start up and shut down the unit again to restore the system.

### Low Suction Pressure Protection

If the low pressure of any system is lower than the set value in the cooling mode (it is not judged during defrosting), the unit will be shut down and give an alarm.

### Suction Antifreezing Protection

If the suction temperature is lower than the set value in the cooling mode, the compressor will be turned off, the water loop electric heating will be started, and the water pump will continue to run.

### Water Switch Detection

The water flow switch detects the “water flow switch detection delay time” after the pump runs. If it is not turned on, the unit will be shut down and give an alarm. The code “FL” will be displayed on the line controller.

If the setting of “full water flow switch detection” is valid and the water flow switches not turned on within the “water flow switch detection delay time” after the water pump is closed, the fault alarm will be given.

### Pump Overload Detection

If the pump is overloaded and tripped, the unit will detect continuously for 5s. If the pump is overloaded and still tripped, the unit will be shut down and give an alarm, and the code “OP” will be displayed on the line controller. Otherwise it will continue to run.

### Compressor Overload Detection

If the compressor of any system is overloaded and tripped, the unit will detect continuously for 5s. If the compressor is overloaded and still tripped, the unit will display the fault code and be shut down.

### High Discharge Temperature Protection

If the discharge temperature of any system is higher than the default protection value, the discharge temperature will be considered too high, and the unit will display the fault code, give an alarm and be shut down.

### Ambient Temperature Overrun Protection

#### Range of Ambient Operating Temperature

Cooling mode	18°C ~ 48°C
Heating mode	-15°C ~ 25°C

If the ambient operating temperature is out of limit, it will be forbidden to start up and a fault code will be given; if the ambient operating temperature is out of limit for 3min after start-up, the unit will be shut down automatically and a fault code will be given.



### **Warning**

**Preheat the unit 24 hours ahead of starting, otherwise the compressor will be damaged. After power on, 40 minutes preheat of compressor is compelled, during this period, the unit unable to start.**  
**If the ambient temperature is lower than 16 °C in winter, do not cut off the power supply.**

### **Automatic Adjustment Protection of Set Heating Temperature**

If the ambient temperature is lower than 0°C in the heating mode, the set heating temperature will be automatically adjusted within the reasonable unit operating range and will not be limited by the set temperature.

### **Flow Protection**

A flow switch (or other flow sensing device) shall be installed on the evaporator pipe to prevent the evaporator from being frozen due to the decrease of water flow. Its set value must ensure that the compressor is immediately stopped when the water quantity is less than 70% of the rated system design flow.



# Module Control System

## System Introduction

The module control system is a highly intelligent modular control system. It can manage the loading and unloading control of multiple outdoor unit modules as well as the modular control of multiple outdoor unit modules through a modular controller, which can control at most 25 units.

Modular controller

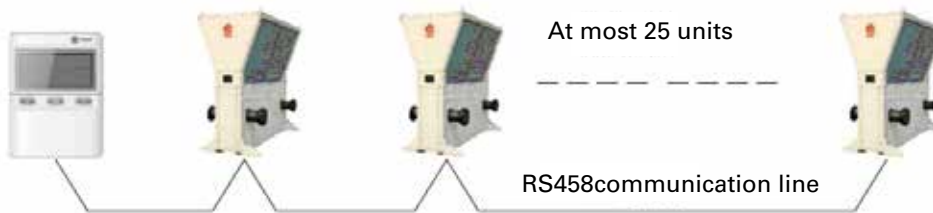

## Modular controller

The modular controller is the core of the whole system. The operation of single unit and group (including start-up and shutdown, temperature setting, mode change, etc.), comfort timing control, network monitoring alarm and other operations can be performed. The configuration of 50\*100mm large LCD and 15 keys provides users with convenient and clear operation interface.

The shell of the modular controller is provided with a turnover cover, the common keys such as 'OK', '^' and 'V' are exposed on the surface, and the normal operation can be performed. More detailed operation can be achieved through the keys below the turnover cover.

The brief instructions for operation keys are printed under the turnover cover.

The modular controller requires 220Vac/12Vdc, 500ma direct current power supply module.

The modular controller is 122\*162\*19.2mm (W\*H\*T) and can be installed through standard 86 box.

## Display, keys and installation of modular controller

### LCD display interface

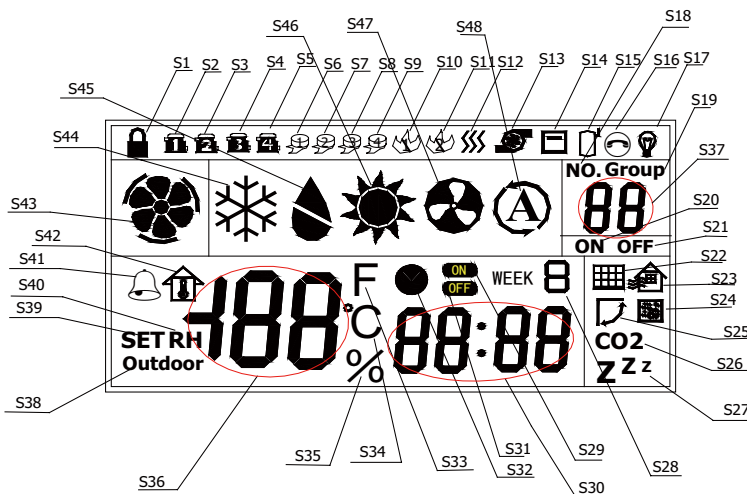



## Module Control System

### Instructions:

- S1 -- Keypad lock; the keypad is locked when the icon is displayed;
- S2~S5 -- Compressors 1~4 starting icons;
- S6~S9 -- Compressors 1~4 defrosting starting icons;
- S10~S11 -- Electric heating 1~2 starting icons ;
- S12 -- An freezing icon;
- S13 -- Pump icon;
- S16 -- Indicating communication problem;
- S17 -- Indicating operation related to light interface board;
- S18 -- Unit number icon, flickering when binding; when the icon is displayed, S37 displays the unit number;
- S19 -- Group operation indication;
- S20 -- Indicating system power-on; in general, it indicates the on/off mode of the unit with minimum number;
- S21 -- Indicating system power-off; in general, it indicates the on/off mode of the unit with minimum number;
- S27 -- Sleep;
- S28 -- Week;
- S29 -- Timing ON mark;
- S30 -- Time, display clock and timer time;
- S31 -- Timing OFF mark;
- S32 -- Timing setting mark. When timing is set, this bit indicates that the timing is effective; in general, this bit indicates that there is timing.
- S33 -- Degree Fahrenheit ;
- S34 -- Degree centigrade;
- S35 -- Percent, used to indicate humidity or compressor loading rate, etc.;
- S36 -- Display temperature, humidity, fault code and other values.
- S37 -- Indicating the total number of units, unit number, etc.;
- S38 -- Unit outlet or external environment temperature display;
- S39 -- Indicating set temperature;
- S40 -- Indicating humidity;
- S41 -- Alarm;
- S42 -- Indicating room temperature;
- S43 -- Fan icon; the outer circle represents the automatic fan, 1 leaf represent low air speed, 2 leaves

leaves medium air speed, and 3 leaves represent high air speed;

S44~S48 -- Respectively representing cooling, dehumidification, heating, ventilation and automatic modes;

Keys



### Instructions:

- ∧ After the modular controller selects the single unit operation mode, press the key, and then the set temperature will rise by 1 °C .Other functions are described below.
- ∨ After the modular controller selects the single unit operation mode, press the key, and then the set temperature will drop by 1 °C .Other functions are described below.
- OK Operation confirmation. Long press the key to perform the group on/off operation.

### Set Time setting key.



- ① Browse key. The key is used for the fast query of network unit status. It can also be used as a number key.
- ② Mode key. After the modular controller selects the single unit operation mode, press the key to change the mode; when setting the time, the key is used to change the month setting. It can also be used as a number key.
- ③ Week key. After the modular controller selects the single unit operation mode, press the key to set the sleep mode; when adjusting the time (or setting the week timing), the key can be used to change the week setting. It can also be used as a number key.
- ④ Single unit key. The key is used for the modular



## Module Control System





---

controller to select the single unit operation mode. It can also be used as a number key.

- ⑤ Fan key. After the modular controller selects the single unit operation mode, the key is used to change the operating speed of the fan; when setting the time, the key can be used to change the date. It can also be used as a number key.
- ⑥ Hour key. When adjusting the time (or setting the week timing), the key can be used to adjust the hour. It can also be used as a number key.
- ⑦ Connect key. The key is used for binding the device network. It can also be used as a number key.
- ⑧ Backlight key. The key is used to control the backlight of the modular controller. It can also be used as a number key.
- ⑨ Minute key. After the modular controller selects the single unit operation mode, the key is used for fault resetting; when setting the time, the key can be used to change the minute. It can also be used as a number key.
- ⑩ Timing key. The key is used for the timing setting of comfort function. It can also be used as a number key.
-  Group key. The key is used for group operation control.
-  Exit key. The key is used for quitting the function of previous key. Long press the key to lock the keypad.

Please refer to the operation instructions on common keys under the turnover cover of the shell for the modular controller.

### Key Instructions

- For unit networking binding, press ⑦.
- For quick query of networked unit, press ⑩.
- For time adjustment, press ② : month; ③ : week; ⑤ : day, ⑥ : hour; ⑨ : minute.
- For single unit operation, press ④ and   temperature setting; ② : mode; ③ : sleep; ⑤ air speed; ⑨ reset.
- For group operation, press  and ② : mode;  : ON/OFF;  : temperature setting.

### Installation of Modular controller

There are four mounting holes at the back of the modular controller, which can be conveniently connected to the standard 86 box.

A 4-core wiring terminal is arranged on the circuit board at the back of the modular controller. Seen from the back of the board, they are 485 signal B, 485 signal A, DC power supply ground (gnd) and DC power supply positive pole (+V). The DC power supply is connected with the communication line through the terminal.

The modular controller is provided with a 220VAC/12VDC, 500mA DC power accessory.

Optimal operating temperature of modular controller: 0-45°C



Module Control System

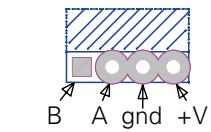
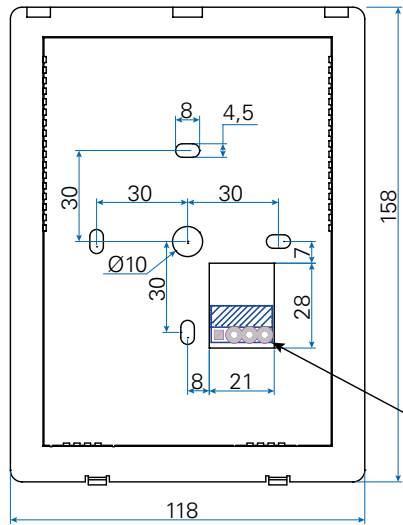

Detail Drawing for Wiring Terminal

Dimensional Drawing for Modular Controller

Wiring Diagram for Modular controller

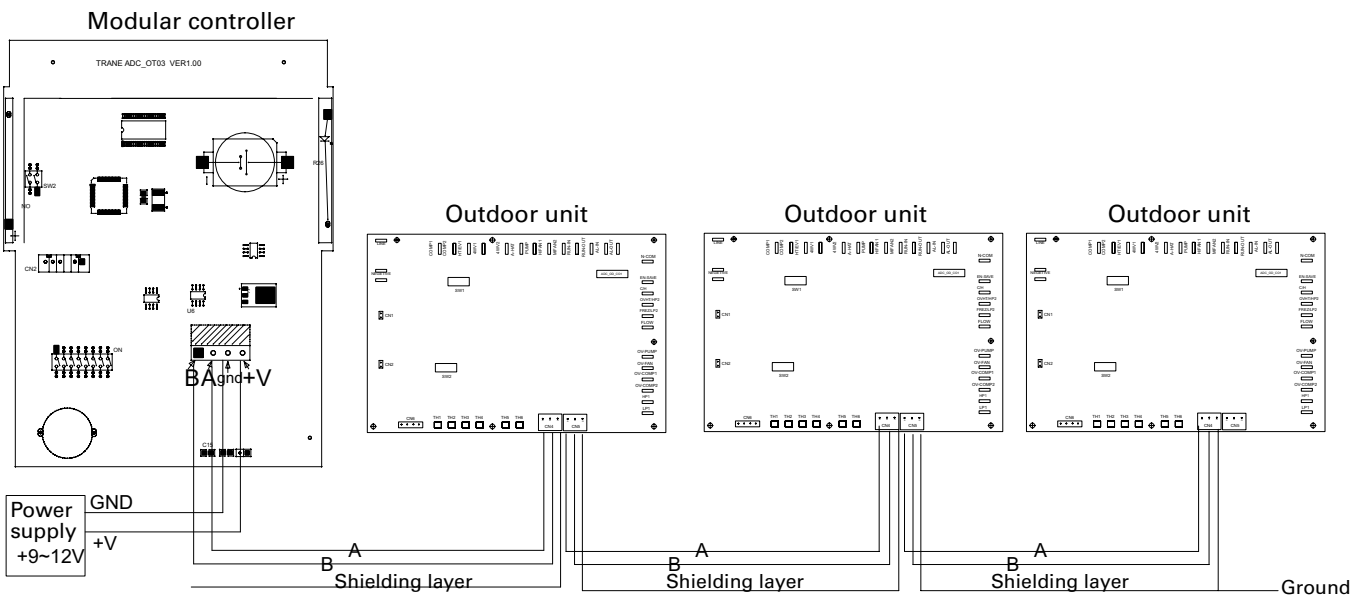



## Module Control System

### Instructions on Ground Terminal of 485 Control Line

It is forbidden to connect to the strong current 220V ground terminal for the metal plate of the electric cabinet.

485 grounding port G is the ground terminal for DC power supply of the electric control board.

### Installation Requirements of 485 Communication Line

- Requirements of communication line: RS485 wire must be AWG # 18 ~ 22 wire with the wire diameter more than 0.75mm<sup>2</sup>, and be a twisted pair with a shielding layer and twist pitch not more than 5cm.
- Hand-in-hand connection requirements: each system module is equipped with two terminals A and B for RS485 connection. In addition to two terminals A and B, the outdoor unit module also has a terminal G for connecting the shielding layer of the communication line. The shielded twisted pair must be connected hand in hand, and no star connection shall be allowed, namely, 1 is connected to 2, 2 is connected to 3, and 3 is connected to 4; if 1 is connected to 2, 2 is connected to 3, and 2 is connected to 4, that connection will be wrong.
- Wiring requirements of shielding layer: after being twisted, the shielding layer shall be wrapped with adhesive tape to prevent it from being connected with 220Vground. One end of the shielding layer shall be connected to the ground point G of the control cabinet for the outdoor unit. When the outdoor unit module is connected, the shielding layer shall be connected to the terminal G. It is forbidden to connect it to the 220V ground terminal of the metal plate for the electric cabinet.
- When the network is unstable, 120ohms and 1uFnetwork terminal resistors connected in series shall be added and installed on the communication ports A and B of the last unit on the network in parallel.

### Unit Address Dial Code Distribution

- Group by unit number

Group 1	No.0 unit	No.5 unit	No.10 unit	No.15 unit	No.20 unit
Group 2	No.1 unit	No.6 unit	No.11 unit	No.16 unit	No.21 unit
Group 3	No.2 unit	No.7 unit	No.12 unit	No.17 unit	No.22 unit
Group 4	No.3 unit	No.8 unit	No.13 unit	No.18 unit	No.23 unit
Group 5	No.4 unit	No.9 unit	No.14 unit	No.19 unit	No.24 unit

*Notes: installation instructions: If there are 6 outdoor*

*units, they should be numbered with 0,1,2,5,6 and 7 and divided into 3 groups; if there are 4 outdoor units, they should be numbered with 0,1,2 and 3 and divided into 4 groups, that is, they should be arranged according to the matrix as far as possible.*

- There are 5 uploading and downloading conditions.

Condition 1 Take the set temperature as the judgement criterion.

Condition 2 Increase the set temperature by 0.5°C (cooling).

Condition 3 Increase the set temperature by 1.0°C (cooling).

Condition 4 Increase the set temperature by 1.5°C (cooling).

Condition 5 Increase the set temperature by 2.0°C (cooling).

*Note: the conditions for heating are reverse.*

- The uploading and downloading conditions for each group are sent by the modular controller:

Adding parameter 0 after the change condition command represents that the group 1 corresponds to condition 1.....The group 5 corresponds to condition 5;

Adding parameter 1 after the change condition command represents that the group 1 corresponds to condition 2.....The group 5 corresponds to condition 1;

Adding parameter 2 after the change condition command represents that the group 3 corresponds to condition 2.....The group 5 corresponds to condition 2;

The change condition command parameters are 0 ~ 4.

*Note: when the sum of module hosts and slaves is less than 5, the change condition command parameters are 0~(the sum of module hosts and slaves minus 1).*

If the unit is not turned off, the modular controller will send the change conditions every 24 hours.

When the outdoor unit is started up each time, the modular controller will send a change condition command.

### System Framework

The module control system is a system that connects a host and multiple slaves through network cables to realize modular control functions. The module control system shares a water pump. The host is responsible for the operation of the water pump in the system, and all the slaves share the water system. The system automatically adjusts the energy balance, controls the time-sharing starting of the unit, and automatically loads and unloads the energy, so as to realize the average wear between units.

### Introduction to Modular Unit



## Module Control System

No.0 outdoor unit is a host, and other outdoor units are slaves.

All units share a water system.

The host is equipped with a system pump and basic input and output.

The host is connected with the pump and detects the water flow switch; the slaves are not connected to the pump, but it is required to be connected with the water flow switch to detect the water flow switch. If the water flow switch of any slave gives an alarm, the slave will be shut down automatically.

The slave has no system pump and interlocking two-way valve, only has basic input and output.

If the host gives an alarm for the pump, all units will be shut down. The slaves have no function of pump alarm.

The host shall be additionally equipped with a "module main outlet water temperature sensor". In cooling condition, the smaller value of the outlet water temperature of each unit and the main outlet water temperature of the module shall be used as the loading, unloading and antifreezing protection condition of the unit. During heating, the outlet water temperature of each unit is used as the loading and unloading condition of the unit.

Do not turn on/off any host and slave or perform the mode conversion by using the unit controller, which can be used for viewing and setting the relevant parameters of the unit.

## Functions of Modular controller

### Function Introduction

- Single unit operation: any single unit on the network can be operated through the modular controller, for example, turn on/off, change mode, change set temperature, etc.
- Multi-unit operation: all networked units on the network can be operated through the modular controller, for example, turn on/off, change mode and adjust temperature; mode and temperature adjustment shall be achieved by operating the host A0.
- Timing operation (comfort control): the temperature value can be set through the modular controller at different times of each day according to working days and rest days within one week to meet the comfort level.
- Network monitoring: all units on the network can be

monitored through the modular controller. When any unit is off the network, it will immediately indicate the number of the unit that is off the network and give an alarm. When one or more units fail, it will immediately indicate the fault code and give an alarm. It can also directly shut down the faulty units on the network.

### Unit Start-up

1. After the unit is connected according to the wiring diagram for the modular controller, the modular controller and the modular unit are powered up, and the modular controller will automatically find the networked units and conduct network search: After the units are connected on the network, the units will be searched firstly. During search, square brackets will be still displayed at the position of air conditioning unit number by flow visualization method. After search, the unit quantity will be displayed at the position of air conditioning unit number. The mode of No.0 unit will be displayed at the position of mode. If more than one networked units are turned on, "ON" will be indicated; if all units are turned off, "OFF" will be displayed, as shown below:



Notes: A. If the online quantity displayed is inconsistent with the actual quantity, inspect whether the connecting line is connected correctly, or confirm whether the unit dial code is correct.

B. If no air conditioning unit is connected after power-on, the modular controller will display the time and indoor temperature; square brackets will be displayed at the position of air conditioning unit number by flow visualization method, indicating that the modular controller is looking for the air conditioning unit on the network, as shown in the figure below:



## Module Control System

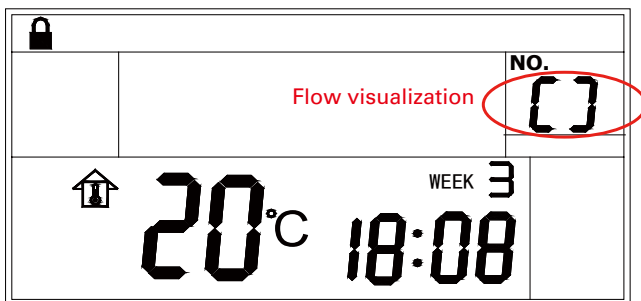

- After the network search is completed without error, adjust the operation mode of the unit as required, and press OK to start up/shut down.

*Notes: A. After receiving the start-up signal, all units will be started up in a delayed manner according to 60s+ unit number \*16s.*

*B. After receiving the shutdown signal, all units will be shut down according to unit number \*8s.*

*C. If the start-up and shutdown interval is too short, the modular controller will still display ON. All units will be completely shut down and in OFF state only after all units accept the shutdown signal.*

- Shutdown method of slaves

A. Select the corresponding single unit according to the single unit operation method. The slave can be turned off, but cannot be turned on.

### Mode Switching

Mode switching must be carried out in the shutdown state. The host A0 can be only selected first to switch mode through the host. Specific switching method:

First select the host A0 (refer to the operation mode for single unit), press Mode to switch the mode, and then press Exit to exit.

### Single Unit Operation

Presses  $\text{Ⓞ}$  (single unit), then 00 will be displayed at the position of air conditioning unit number and flicker; press  $\text{^}$ , then A0 will be displayed at the position of air conditioning unit number; press  $\text{v}$  and  $\text{^}$ , then the unit number will vary from A0 to BF, and then press OK. If the air conditioning unit exists on the network, the air conditioning unit number will stop flickering, indicating that the unit is selected for control, and then the unit can be controlled.

If Exit is pressed at this time, the single unit operation will be quit. Press  $\text{Ⓞ}$  (single unit) to select other units to operation.

### Modification of Control Parameters through

### Modular controller (Only Valid in Off State)

Firstly select the host A0 (see the single unit operation mode);

Then press  $\text{Ⓞ}$  (group) for 3 seconds, then the lock symbol will be displayed at the upper left corner and flicker; at this time, the unit number also flickers; enter the password 66 through the number keys; press OK to enter parameter modification.

At this point, the parameter ID will be displayed at the position of time, and the parameter value will be displayed at the position of temperature. At this time, press  $\text{v}$  and  $\text{^}$  to respectively modify the parameters. After modification, press OK to confirm changes, and enter the next parameter modification. If no changes are made, press  $\text{0}$  to enter the next parameter.

*Note 1: if no parameters of the unit can be modified, press OK to quit the mode of parameter modification.*

*Note 2: if the parameter is temperature, the unit 'C' or 'F' will be displayed; if the parameter is time or other parameter, no unit will be displayed.*

*Note 3: The decimal part of the parameters will not be displayed.*

Password "66" Setting	
Code	Set Value
16	Set cooling temperature
17	Set heating temperature
22	Winter antifreezing inlet water temperature
01	Defrosting interval
02	Minimum defrosting time

### Fast Query

When  $\text{Ⓞ}$  (Browse) is pressed for more than 1 second, the display screen will display the operating state of the unit with minimum number. Then the unit number is automatically increased (the automatically increased speed can be adjusted. See 3.161). Continue to browse downward. When  $\text{v}$  is pressed, the unit number will stop increasing; when  $\text{v}$  is pressed again, the unit number will be increased automatically. When the unit number stops increasing, press  $\text{^}$ , and then the unit number is minus 1, and other units are displayed reversely. Press Exit to quit browsing. See the figure below:



## Module Control System

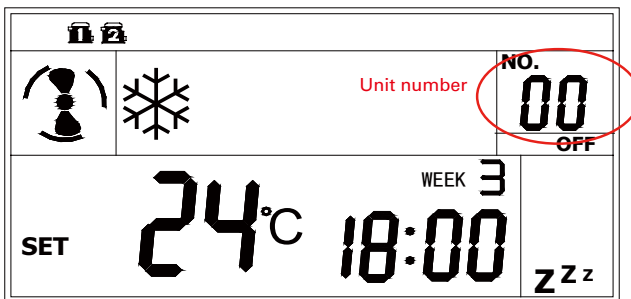

### Fault Display

- Offline display:  
Under normal circumstances, the quantity of units on the network is displayed at the position of unit number, and "NO." is not displayed. If there are offline units, "NO." will be displayed, and the number of offline unit will be displayed at the position of unit number and flicker, and the telephone icon will be displayed. If more units are offline, the unit number will be displayed in turn.

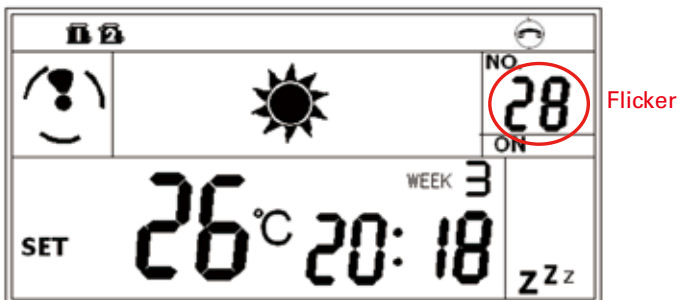

- Unit fault display:  
In case of failure of the unit on the network, the number of faulty unit on the network will be displayed at the position of unit number, the alarm symbol and the fault code will be displayed in the temperature display area, as shown below. **If there are more faulty units, they will be displayed in turn, and there will be an alarm sound. At this time, press Exit to cancel the alarm sound, or press OK to shut down the faulty unit; press @ to send the fault reset signal to the faulty unit.**

### In case of unit fault:

In case the pump and the water flow switch of the host fail, the unit will be shut down when the slave receives the command; the salve will display the system fault of the host.

In case of other faults on the host, not pump fault, the pump cannot be closed.

The salve fault can be handled as the case may be.



### Setting of Outlet Temperature or Display Outlet Temperature for Modular Controller

Press 'V' for 3 seconds to enter the password mode, then the lock symbol will be displayed at the upper left corner, and the unit number will flicker. Enter the two-digit password (the default is 00), press 'OK', the lock symbol and the unit number flicker simultaneously, and then enter the adjustment interface. At this time, press 'V' to display set temperature or outlet water temperature.

### Keyboard Locking

When pressing Exit for more than 6 seconds, the lock icon will be displayed at the upper left corner of the LCD;

At this point, press Exit again for more than 6 seconds, then the keyboard locking is released.

During keyboard locking, no key operation will be allowed.

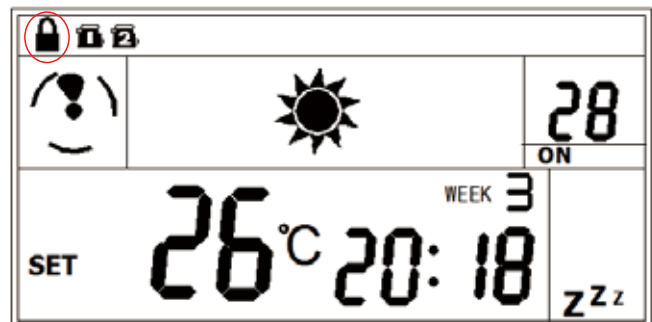

### Time Adjustment

When SetTime is pressed for more than one second, the time display part flickers.

And then press @ (Week), @ (hour) and @ (minute) to adjust week, hour and minute respectively. If these keys are long pressed, week, hour and minute will change



## Module Control System

quickly.

Press ② (Month) to adjust month, and press ⑤ (Day) to adjust day.

After adjustment, press SetTime to change the clock and quit the time adjustment.

If the user presses Exit instead of SetTime, the clock does not change.

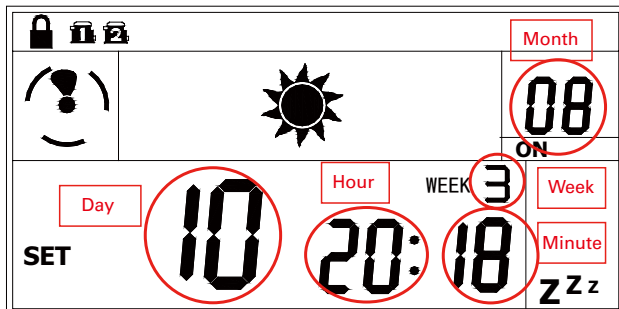

*Note: after the master controller is installed for the first time or the battery is replaced, the clock must be adjusted; otherwise, the clock will not work, and the balance running time will be invalid.*

### Timing Control

This timing setting corresponds to all units on the network. Even if only a single outdoor unit is connected, the timing control will be executed.

The timing setting only corresponds to the software version number of 3.71. Simultaneously press ① and ④ (group) for 5 seconds to view the software version.

There are two control modes in each week: off day and working day, which can be disabled and activated respectively.

Each day is divided into four time periods -- time period 1, time period 2, time period 3 and time period 4 (the default name of the system can be modified in the computer interface). In these four time periods, turning on/off the air conditioning unit can be set respectively. In addition, four time periods can also be modified.

The four time periods are arranged in ascending order, i.e., the former time period cannot exceed the latter time period. If the time period 2 is set to 10:00, the time period 1 must be set to 0:00 ~ 9:59. Long press Hour to skip the time limit.

When there is timing control, the master controller S32 icon will be displayed.

### Setting of Working Days (Monday to Friday)

Press ① Timing for 5 seconds to display at the position

of Week, indicating that the program control set below acts on the working time.

1 will be displayed at the position of air conditioning unit number, which indicates that the set time is time period 1;

If 2 is displayed at the position of air conditioning unit number, it will indicate that the set time is time period 2; if 3 is displayed, the set time will be time period 3; if 4 is displayed, the set time will be time period 4.

At this point, press ⑥ to set hour, and press ⑦ to set minute.

If the user presses 'OK', OFF will be displayed, indicating that the unit will be shut down at this time.

If the user presses 'OK' again, ON will be displayed, indicating that the unit will be started up at this time.

After the setting is completed, press Timing to set the time of the next time period;

Press ⑧ during setting to select whether this timing mode is effective. If any, ⑨ will be displayed; if not, ⑩ will not be displayed.

When all time settings are completed, press Timing to save and exit. Press Exit to exit but not to save.

### Setting of Off Days (Saturday and Sunday)

Press ③ for 5 seconds, then H will be displayed at the position of Week, indicating that the program control set below acts on the off days;

1 will be displayed at the position of air conditioning unit number, which indicates that the set time is time period 1;

If 2 is displayed at the position of air conditioning unit number, it will indicate that the set time is time period 2; if 3 is displayed, the set time will be time period 3; if 4 is displayed, the set time will be time period 4.

At this point, press ⑥ to set hour, and press ⑦ to set minute.

If the user presses 'OK', OFF will be displayed, indicating that the unit will be shut down at this time.

If the user presses 'OK' again, ON will be displayed, indicating that the unit will be started up at this time.

After the setting is completed, press Timing to set the time of the next time period;

After the setting is completed, press ⑧ to set the time of the next time period;

When all settings are completed, press ③ to save and exit. Press Exit to exit but not to save.



## Module Control System

Press during setting to configure whether this timing mode is effective. If any, will be displayed.

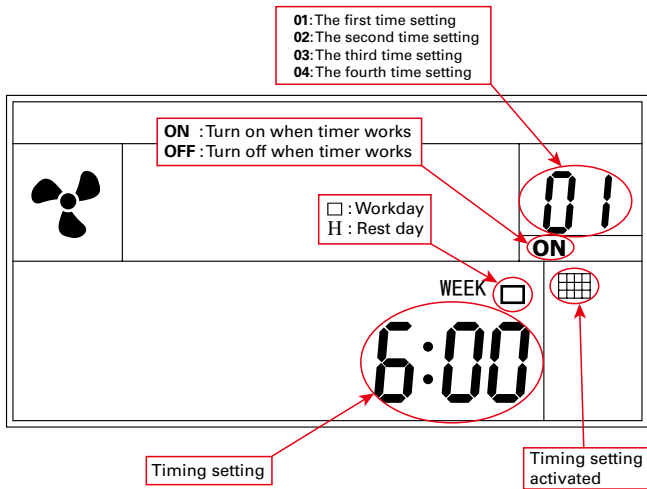

*Note 1: Week cannot be adjusted. Monday to Friday are working days by default; Saturday to Sunday are off days*

*Note 2: the timing is set for all units on the master controller network, namely, all units perform this timing setting.*



## Building Control System

Mini-ICS system is a highly intelligent modular control system specially developed by Trane for Unitary (small and medium sized) units. It can manage the linkage control of multiple indoor and outdoor units, the loading and unloading control of multiple outdoor unit modules, the modular control of multiple outdoor units and the modular control of multiple indoor units. It is connected with Modbus communication module, can realize the monitoring of local computer and the remote control of Internet: remote setting of room temperature, operating mode and on/off, and fault alarm.

According to the number of master controllers, the system can be divided into a single-master-controller system and a multi-master-controller system. The single-master-controller system is suitable for comfortable air conditioning control of multiple rooms in a single family; the multi-master-controller system is suitable for the control of multiple units in a small commercial system.

The modular control system consists of modular controllers, Modbus communication modules, hubs,

units and other devices. It can control the whole air conditioning system remotely and centrally and provide the required data to the BA system, so that it can be connected to the building automatic control system.

### Modbus component (Optional) -- Connected to Third-party BA System

Modbus component is a professionally designed protocol conversion device and interface, through which the multi-master-controller system is connected. A Modbus component corresponds to a modular controller. The module can convert Trane internal communication protocol into an open Modbus protocol for the third-party system.

Modbus component is generally used in the multi-master-controller system, and its upstream and downstream are RS485 network interfaces. Each module corresponds to a modular controller. For the specific connection diagram, see the figure below:

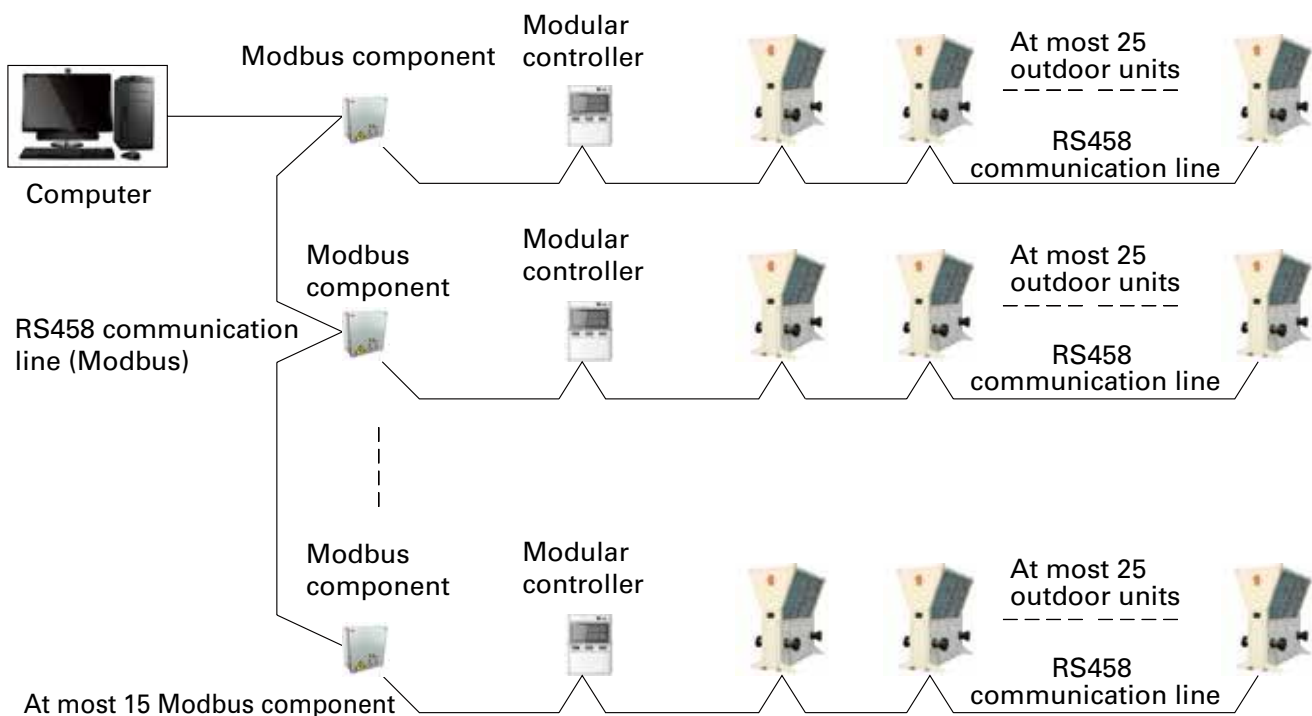

For the specific wiring and operation of Modbus components, see Operation Manual for CXAJ Series Modbus components.



# Troubleshooting

## Fault Codes

No.	PCB Port	Fault Description	Code on unit controller	Code on Modular controller	Fault Handling
1	TH1	No.1 analog sensor fault	20	20	Shut down
2	TH2	No.2 analog sensor fault	21	21	Shut down
3	TH3	No.3 analog sensor fault	22	22	Shut down
4	TH4	No.4 analog sensor fault	23	23	Shut down
5	TH5	No.5 analog sensor fault	24	24	Shut down
6	TH6	No.6 analog sensor fault	25	25	Shut down
7	TH7	No.7 analog sensor fault	26	26	Shut down
8	TH8	No.8 analog sensor fault	27	27	Shut down <sup>2</sup>
9	TH9	No.9 analog sensor fault	28	28	Shut down <sup>2</sup>
10	TH10	No.10 analog sensor fault	29	29	Shut down <sup>2</sup>
11	TH11	No.11 analog sensor fault	2A	2A	Shut down <sup>2</sup>
12	TH12	No.12 analog sensor fault	2B	2B	Shut down <sup>4</sup>
13	CN13	No.13 analog sensor fault	2C	2C	Shut down
14	CN14	No.14 analog sensor fault	2D	2D	Shut down <sup>2</sup>
15	IND3	High-pressure alarm of systemA	H2	65	Shut down <sup>2</sup>
16	IND4	High-pressure alarm of systemB	H1	64	Shut down
17	IND5	Water flow switch alarm	FL	6D	Shut down
18	IND6	Overload of water pump	OP	6A	Shut down
19	IND8	Overload of compressor 1	C1	68	Shut down
20	IND9	Overload of compressor 2	C2	69	Shut down <sup>2</sup>
21	CN13	Low-pressure alarm of systemA	L1	66	Shut down
22	CN14	Low-pressure alarm of systemB	L2	67	Shut down <sup>2</sup>
23	TH2 and TH1-TH2	Freezing protection	E3	8D	Shut down all compressors, and keep the pump continuously running <sup>1</sup>
24	TH3、TH8	Abnormal suction temperature	E4	91	Shut down all compressors, and keep the pump continuously running <sup>1,2</sup>
25	CN13	Low pressure overrun A	78	78	Shut down the compressors of the system A. If the fault occurs for two times within 1 hour, shut down and give an alarm.
26	CN14	Low pressure overrun B	7A	7A	Shut down the compressors of the system B. If the fault occurs for two times within 1 hour, shut down and give an alarm <sup>2</sup>
27	TH4、TH9	Coil superheating	98	98	Shut down <sup>2</sup>
28	TH7	Ambient temperature out of range	87	87	Shut down
29	CN29	Communication failure between PCB and modular controller	ED	-	Shut down
30	CN4/XP1	Communication failure between unit controller and PCB	EE	-	Shut down
31	TH5,TH6, TH10,TH11	Abnormal discharge temperature	AC,AD, AE,AF	AC,AD, AE,AF	Shut down
32	CN15	No.15 analog sensor fault (discharge pressure A)	2E	2E	Shut down
33	CN16	No.15 analog sensor fault (discharge pressure B)	2F	2F	Shut down
34	///	Unit locked	E0	E0	Forbid starting
35	///	Water inlet and outlet connected reversely	A0	A0	Shut down and alarm



## Troubleshooting

36	///	Configuration error fault	E1	E1	Forbid starting
37	///	System high and low Pressure abnormal alarm	A4	A4	Shut down and alarm

Instruction: the faults in the table are only displayed on the line controller and the modular controller.

*Note 1: when this fault occurs, shut down all compressors, keep the pump running, and lock the unit for "cooling shell antifreezing locking time". When the outlet water or suction temperature returns to normal, the manual fault reset may be allowed.*

*Note 2: for CXAJ065 units, there are no TH8, TH9, TH10, TH11, CN14, IND3 and IND9 inputs and relevant alarm codes.*

*Note 3: this alarm code is available only when "module control" is selected.*

*Note 4: this alarm code is only available when "module control" is selected and it is module host.*

## Common Faults and Handling Methods

Fault	Possible Causes	Detection and Eliminating Methods
The unit fails to start up	1. The unit is not powered on	Power on the unit
	2. The main switch is not turned on	Turn on the main switch
	3. The control circuit is not energized	Turn on the power supply of the control circuit
	4. The unit fails (gives an alarm)	Find out the alarm cause and solve it
	5. The main outlet water temperature probe is faulty or damaged	Inspect whether the main outlet water temperature probe is correct or damaged
	6. The outlet water temperature reaches the set temperature value	Start after the water temperature drops
	7. The water system fails and the water flow switch is disconnected	Ensure the appropriate water flow
	8. The power supply has incorrect phase sequence and inverse phase protection	Change the position of two phases in the power supply
The compressor fails to start	1. The compressor is not powered on	a. Inspect the compressor wires
	2. The thermal protection switch acts	Find out the cause before the protection switch is reset
	3. The motor is short-circuited	Inspect and replace the compressor
	4. The contactor is damaged	Replace the contactor
	5. Internal protection of compressor	a. Inspect the compressor current; b. Wait for the resetting of internal contact for the compressor (about 20 minutes)
	6. Motor stalling of compressor	a. Inspect the compressor coil resistance; b. Replace the compressor if damaged.
The compressor fails to unload	1. The current units can not meet load	Add the units
	2. The outlet water temperature probe is wrongly placed or damaged	a. Inspect the position of outlet water temperature probe; b. Inspect the resistor of the outlet water temperature probe, and confirm whether it is damaged.
	3. The motor is short-circuited	Replace the compressor
	4. The contactor is damaged	Replace the contactor
	5. The refrigerant leaks and the unit capacity is declined	a. Find out the leak point; b. Add refrigerant
The compressor sounds abnormally	1. The internal parts are damaged	Replace the compressor
	2. The compressor entrains liquid	a. Adjust superheat; b. Inspect whether the refrigerant is excessive



## Troubleshooting

Fault	Possible Causes	Detection and Eliminating Methods
The compressor is shut down due to overload	Excessively low or high voltage	Inspect the voltage, which shall not be more than lower than 10% of the rated voltage. The phase unbalance shall not exceed 4.5%.
	Excessively low or high discharge pressure	Inspect whether the refrigerant system is fouled and blocked and whether the expansion valve is normal
	Excessively high water temperature (heating)	Inspect whether the water flow is too low and whether the waterway filter is fouled and blocked
	Overload element failure	Change the overload protector
	Excessively high ambient temperature	The operating range is out of limit
	The motor or wiring terminal is short-circuited	Inspect the compressor coil resistance
The temperature protection switch in the compressor acts and the compressor is shut down	Excessively low or high voltage	Inspect the voltage, which shall not exceed the above requirement
	Excessively high discharge pressure	Inspect the discharge pressure and find out causes
	Excessively high chilled water inlet temperature	
	The temperature protection switch in the compressor fails	Inspect the chilled water inlet temperature and find out causes
	Insufficient system refrigerant	Inspect whether fluorine leaks, repair and fill fluorine
The unit has poor cooling effect or no cooling capacity in summer	1. The position of the suction temperature probe is wrong	Inspect and install the suction temperature probe at the correct position
	2. The refrigerant leaks	Find out the leak point, repair and fill the refrigerant
	3. The four-way reversing valve leaks or is damaged (heat pump)	Replace the four-way valve
	4. The expansion valve is damaged	Replace the expansion valve
	5. The system is mixed with air and other non-condensable gases	Exhaust air from the condenser or the liquid storage tank
	6. The surface of the condenser fin is dirty or the heat exchange tube of the evaporator is scaled	Clean the condenser and the evaporator
	7. The unit is small and the actual load is large	Increase the units
The unit has poor heating effect or no heating capacity (heat pump)	1. The refrigerant leaks	Find out the leak point, repair and fill the refrigerant
	2. The position of the suction temperature probe is wrong	Inspect and install the suction temperature probe at the correct position
	3. The four-way reversing valve leaks or the coil is burnt	Replace the four-way valve or the coil
	4. The expansion valve is damaged	Replace the expansion valve
	5. The unit is small and the actual load is large	Increase the units



## Troubleshooting

Fault	Possible Causes	Detection and Eliminating Methods
High pressure protection	1. The ambient temperature is too high and out of temperature range	Restore after the ambient temperature drops
	2. The condensate fan fails	Repair or replace the condensate fan
	3. The unit is shut down at high pressure, and the set value is wrong	Inspect the high pressure and the pressure controller
	4. Excessive fluorine	Inspect the fluorine filling quantity, and drain part of refrigerant
	5. The system is mixed with air and other non-condensable gases	Exhaust air from the condenser or the liquid storage tank
	6. The defrosting (heat pump) time is too long	Reasonably set the defrosting time
	7. The four-way reversing valve is damage	Replace the four-way valve
	8. The waterway water flow is low (during heating)	Inspect the waterway system and the filter
	9. The high pressure switch is damaged	Inspect the low pressure switch line. If the low pressure switch is damaged, replace parts.
Low pressure protection	1. The expansion value fails	Repair or replace the thermal expansion valve
	2. The pipeline is blocked	Remove blockage
	3. The unit leaks	Find out the leak point and fill refrigerant
	4. The fan is damaged (during heating)	Inspect the fan
	5. The refrigerant is insufficient	Fill refrigerant
	6. The ambient temperature is too low	The ambient temperature is lower than the unit allowable operating temperature. The unit shall be shut down.
	7. The lower pressure switch is damaged	Inspect the low pressure switch line. If the low pressure switch is damaged, replace parts.
	8. The water flow is too low	Inspect the waterway system and the filter
For the double-system unit, the pressure of one system suddenly drops, and the pressure of the other system rises.	The evaporator leaks and streams	Remove the end cover, replace the washer, and tighten the bolt
The pressure sensor fails	1. The inspection interface is not plugged tightly	Plug again
	2.The pressure sensor is damaged	Replace parts
	3. The unit leaks refrigerant	Find out the leak point, and fill refrigerant
	4.PCB socket is damaged	Replace PCB
The temperature sensor fails	1. The inspection interface is not plugged tightly	Plug again
	2.The temperature sensor is damaged	Replace parts
	3.PCB socket is damaged	Replace PCB



## Maintenance and Service

Routine maintenance and servicing shall be done by qualified professionals. In order to keep the normal operation of the unit, extend the service life of the unit and reduce the possibility of failure, please regularly carry out the following inspection items, make adjustments and necessary maintenance, and keep records, which is helpful for the maintenance personnel to diagnose the unit failure.

### Daily Regular Inspection

1. Please inspect whether the condenser is dusty, and clean the condenser if necessary. If the fin double-pipe heat exchanger is seriously polluted, the unit performance will be reduced.
2. Clean the contaminated fan blades regularly.
3. Inspect vibration and running sound regularly to confirm whether there are abnormal compressor noises, abnormal vibration and other abnormal sounds. In case of abnormal sound, inspect the fault position and find out causes. If the cause is unknown, please contact the manufacturer or dealer.
4. Please inspect the host, for example, whether the electric cabinet is loose and whether there is leakage or abnormal vibration in the pipeline.
5. Please inspect whether air is mixed into the water piping system. Even if the system is exhausted, sometimes there will be air mixed into the system. Please exhaust air at regular intervals.
6. Please inspect and clean the water filter. Professional assistance will be required if the water loop is required to be cleaned.
7. Please confirm the water quality regularly. If the water quality is reduced, please replace the contaminated water in the system. Contaminated water will reduce cooling capacity and corrode heat exchangers or water pipes.
8. Please regularly inspect the valves and pipes in the water loop, inspect whether the pipes are connected tightly, and inspect the water pump and related parts.
9. Please regularly inspect and record the pressure, temperature and other parameters to see if they are within the normal range, and record the inspection and maintenance time.

### Warnings

1. **Before making any contact, please be sure to turn off the main power supply, otherwise it may cause casualties and damage to the unit.**
2. **It is very important that the maintenance and servicing should be carried out by qualified professionals at least every six months or every 1,000 RPH.**

### Inspection and Cleaning of Condenser

In order to ensure the effective operation of condenser, the outer layer must be free from any fallen leaves, cotton threads, insects, slag shells and other contaminants. If there is dirt on the condenser, it will not only increase the power consumption, but also cause too high operating pressure, failure shutdown and other problems.

When the condenser is required to be cleaned, the compressed air is blown to the aluminum foil heat exchanger in parallel from inside to outside, which is just opposite to the air flow direction of normal unit operation. For external cleaning, use a vacuum cleaner. Do not damage the aluminum foil heat exchanger. Be careful not to be scratched by the fins when cleaning.

The condenser can be cleaned with brush or water column. Wash the condenser from inside to outside when cleaning with water column. If the pipe bank is too dirty, please contact professional cleaning personnel.

### Warning

**Never clean the condenser with steam, otherwise it will cause the internal pressure to rise and the refrigerant to leak out from the safety valve.**

### Inspection and Cleaning of Evaporator

Please regularly inspect the water temperature of the evaporator inlet and outlet, and compare it with the saturated evaporation temperature during cooling or the saturated condensation temperature during heating. For the evaporator effectively working, the average water temperature at the inlet and outlet shall be 3-8 °C different from the refrigerant saturated evaporation temperature during c or the refrigerant saturated condensation temperature during heating.

If the difference is greater than the range, it will indicate that the efficiency of the heat exchanger has decreased.



---

As some chemical treatment is required in the cleaning process of the heat exchanger, cleaning must be done by professionals.

### **Charge of Refrigerant and Lubricant**

Each unit is filled with the appropriate refrigerant and the corresponding lubricating oil. If the cooling circulating system works normally and maintenance or other servicing is not required, do not fill or replace refrigerant and lubricant at will. Under normal conditions, the refrigerant and lubricating oil inside the machine can be used all the time. If the refrigerant must be refilled due to leakage, please refer to the unit nameplate parameters.

Be sure to vacuum the system below 46Pa before refilling the refrigerant.

### **Inspection and Cleaning of Water Flow Switch (for Model with Water Flow Switch)**

As impurities cannot be avoided in water, there will be impurities accumulated in the water flow switch with the increase of service time, affecting the reliable operation of water flow switch. It is suggested that the customers clean or replace the water flow switch every two years. If the water quality of the water system is poor, the cleaning or replacement cycle shall be shortened.



## Name and Content of Hazardous Substances In product

Part Name	Hazardous Substances					
	Lead (Pb)	Mercury (Hg)	Cadmium (Cd)	Hexavalent chromium Cr(VI)	Polybrominated biphenyls (PBB)	Polybrominated diphenyl ethers (PBDE)
Motor	×	○	×	○	○	○
Heat exchanger core	○	○	○	○	○	○
Filter	○	○	○	○	○	○
Screw, bolt and other fasteners	○	○	○	○	○	○
Sheet metal plate	○	○	○	○	○	○
Thermal insulation and damping blocks	○	○	○	○	○	○
Plastic parts	○	○	○	○	○	○
Foam parts	○	○	○	○	○	○
Rubber parts	○	○	○	○	○	○
Power line and communication line	×	○	○	○	○	○
PCB and electrical components	×	○	×	○	○	○
Printed parts	○	○	○	○	○	○
Controller parts (controller/battery)*	×	○	×	○	○	○
Other seal components	○	○	○	○	○	○
Other stamp class	○	○	○	○	○	○

This table is prepared in accordance with SJ/T 11364.

○ : Indicates that the content of the hazardous substance in all homogeneous materials of the component is below the limit specified in GB/T 26572.

× : indicates that the content of the hazardous substance in at least one homogeneous material of the component exceeds the limit specified in GB/T 26572. However, it is temporarily impossible to realize that the product parts do not contain any of the above hazardous substances in the current technical conditions. Subsequently, with the progress of alternative technologies, the content of hazardous substances will be gradually reduced.



## Environmental Safety Warning

### **Warning:**

Please read the following instructions carefully before opening the refrigerant system of the unit for maintenance. Failure to do so may result in personal injury or death:

1. Refrigerant frostbite risk: please confirm that the pressure in the refrigerant system is completely the same as that outside, otherwise there may be a risk of refrigerant frostbite.
2. Heating explosion risk of pressure components: before heating the refrigerant system, please confirm that the pressure in the refrigerant system is completely the same as that outside and reserve vents, otherwise there may be a risk of heating explosion of pressure components.
3. Combustion risk of refrigerant oil: before heating the refrigerant system, please confirm that the refrigerant oil in the system has been completely removed. If it is not possible to remove the refrigerant oil in the system and the refrigerant system is required to be opened, it is recommended that the cold processing method be used, such as pipe cutter, etc.

### **Notice:** Please follow the following rules. Any violation may cause irreversible damage to the unit:

1. If the user needs to add refrigerant, please contact our designated after-sales service agency for confirmation.
2. Do not add additives to the refrigeration system.
3. Replace refrigerating oil and refrigerant after the compressor burns out.

### **Notice:** Please take environmental protection into consideration when repairing or scrapping the unit:

1. During the maintenance of the water system, please consider whether there are additives such as ethylene glycol in the system, and ask the qualified supplier to dispose of them.
2. When maintaining the refrigerant system, ask the qualified supplier to dispose of refrigerant and refrigerant oil in the system.
3. When the units or parts are scrapped, please consider the impact on environmental resources, and ask the qualified supplier to dispose of them.

Category	Disposal Method
Steel parts	Recycle
Copper products	Recycle
Aluminum products	Recycle
Refrigerant	Recycled by qualified supplier
Refrigerant oil	Hazardous waste disposal supplier
Rubber and plastic products	Hazardous waste disposal supplier
Electronic components	Electrical and electronic waste recycling enterprise

### **Notice:** The following wastes are hazardous wastes and shall be disposed by the owner according to the relevant requirements of the local environmental protection department:

1. Waste refrigerator oil generated during the maintenance, replacement and disassembly of refrigeration equipment compression equipment (HW08 waste mineral oil and waste containing mineral oil 900-219-08)
2. Waste acid solution generated during cleaning with acid (HW34 waste acid 900-300-34).



Trane - by Trane Technologies (NYSE:TT), a global climate innovator - creates comfortable, energy efficient indoor environments for commercial and residential applications. For more information, please visit [trane.com](http://trane.com) or [tranetechnologies.com](http://tranetechnologies.com).

Trane has a policy of continuous product and product data improvement and reserves the right to change design and specifications without notice. We are committed to using environmentally conscious print practices.